

Relay Output Modules

F2-08TRS Relay Output <--->	
Outputs per Module	8
Outputs Points Consumed	8
Commons per Module	8 (isolated)
Output Type	3, Form C (SPDT) 5, Form A (SPST normally open)
Operating Voltage	7A @ 12-28 VDC, 12-250 VAC 0.5A @ 120VDC
Peak Voltage	150 VDC, 265 VAC
ON Voltage Drop	N/A
AC Frequency	47 to 63Hz
Minimum Load Current	10mA @ 12 VDC
Max Load Current (resistive)	7A/point ³ (subject to derating)
Max Leakage Current	N/A
Max Inrush Current	12A
Base Power Required 5VDC	670 mA
OFF to ON Response	15 ms (typical)
ON to OFF Response	5ms (typical)
Terminal Type (included)	Removable; D2-16IOCON
Status Indicator	Logic side
Weight	5.5oz. (156g)
Fuses	None

Typical Relay Life' (Operations) at Room Temperature			
Voltage & Type of Load ²	Load Current		
	50mA	5A	7A
24 VDC Resistive	10M	600k	300k
24 VDC Solenoid	-	150k	75k
110 VDC Resistive	-	600k	300k
110 VDC Solenoid	-	500k	200k
220 VAC Resistive	-	300k	150k
220 VAC Solenoid	-	250k	100k

1) Contact life may be extended beyond those values shown with the use of arc suppression techniques described in the DL205 User Manual. Since these modules have no leakage current, they do not have built-in snubber. For example, if you place a diode across a 24 VDC inductive load, you can significantly increase the life of the relay.

2) At 120 VDC 0.5A resistive load, contact life cycle is 200k cycles.

3) Normally closed contacts have 1/2 the current handling capability of the normally open contacts.

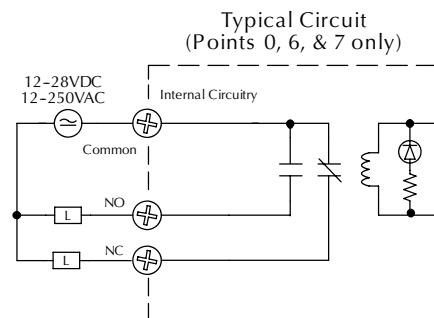
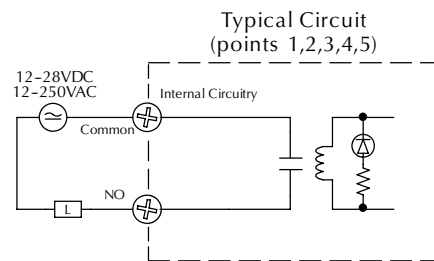
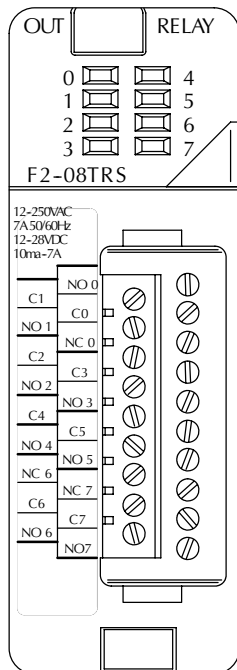
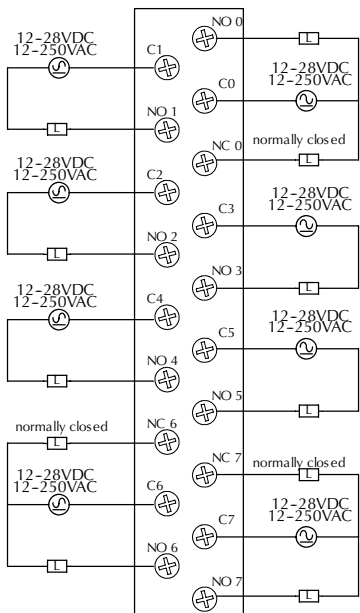
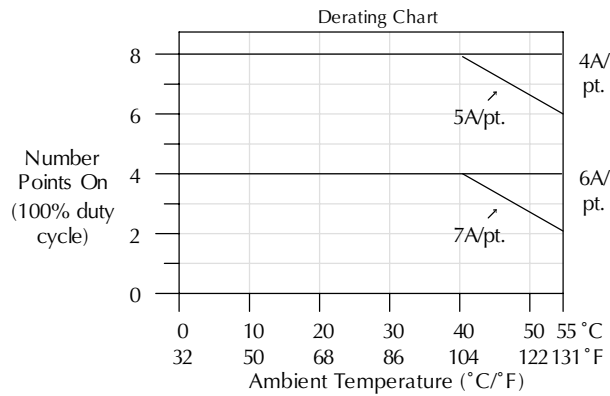

- PLC Overview
- DL05/06 PLC
- DL105 PLC
- DL205 PLC**
- DL305 PLC
- DL405 PLC
- Field I/O
- Software
- C-more HMIs
- Other HMI
- AC Drives
- Motors
- Steppers/Servos
- Motor Controls
- Proximity Sensors
- Photo Sensors
- Limit Switches
- Encoders
- Pushbuttons/Lights
- Process
- Relays/Timers
- Comm.
- TB's & Wiring
- Power
- Enclosures
- Appendix
- Part Index