

F2-04THM

4-Channel

Thermocouple Input

7

In This Chapter. . . .

- Module Specifications
 - Setting The Module Jumpers
 - Connecting the Field Wiring
 - Module Operation
 - Writing the Control Program
-

Module Specifications

The F2-04THM 4-Channel Thermocouple Input Module provides several features and benefits.

- Four thermocouple input channels with 16-bit voltage resolution or 0.1 °C/°F temperature resolution.
- Automatically converts type E, J, K, R, S, T, B, N, or C thermocouple signals into direct temperature readings. No extra scaling or complex conversion is required.
- Temperature data can be expressed in °F or °C.
- Module can be configured as ±5V, ±156mV, 0-5V or 0-156 mV and will convert volts and millivolt signal levels into 16-bit digital (0-65535) values.
- Signal processing features include automatic cold junction compensation, thermocouple linearization, and digital filtering.
- The temperature calculation and linearization are based on data provided by the National Institute of Standards and Technology (NIST).
- Diagnostic features include detection of thermocouple burnout or disconnection.

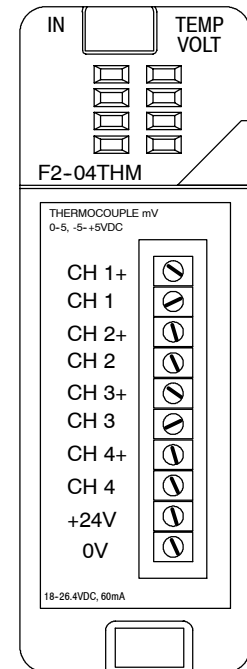

The following tables provide the specifications for the F2-04THM Analog Input Module. Review these specifications to make sure the module meets your application requirements.

General Specifications

Number of Channels	4, differential
Common Mode Range	±5VDC
Common Mode Rejection	90dB min. @ DC, 150dB min. @ 50/60 Hz.
Input Impedance	1MΩ
Absolute Maximum Ratings	Fault-protected inputs to ±50 VDC
Accuracy vs. Temperature	±5 ppm/°C maximum full scale calibration (including maximum offset change)
PLC Update Rate	4 channels per scan max. DL240/250-1/260 CPU 1 channel per scan max. DL230 CPU
Digital Inputs Input Points Required	16 binary data bits, 2 channel ID bits, 4 diagnostic bits 32 point (X) input module
External Power Supply	60 mA maximum, 18 to 26.4 VDC
Power Budget Requirement	110 mA maximum, 5 VDC (supplied by base)
Operating Temperature	0 to 60° C (32 to 140° F)
Storage Temperature	-20 to 70° C (-4 to 158° F)
Relative Humidity	5 to 95% (non-condensing)
Environmental air	No corrosive gases permitted
Vibration	MIL STD 810C 514.2
Shock	MIL STD 810C 516.2
Noise Immunity	NEMA ICS3-304

One count in the specification table is equal to one least significant bit of the analog data value (1 in 65535).

Thermocouple Specifications

Input Ranges	Type J -190 to 760°C -310 to 1400°F Type E -210 to 1000°C -346 to 1832°F Type K -150 to 1372°C -238 to 2502°F Type R 65 to 1768°C 149 to 3214°F Type S 65 to 1768°C 149 to 3214°F Type T -230 to 400°C -382 to 752°F Type B 529 to 1820°C 984 to 3308°F Type N -70 to 1300°C -94 to 2372°F Type C 65 to 2320°C 149 to 4208°F
Display Resolution	± 0.1°C / ± 0.1°F
Cold Junction Compensation	Automatic
Warm-Up Time	30 min. typically ± 1°C repeatability
Linearity Error (End to End)	± .05°C maximum, ± .01°C typical
Maximum Inaccuracy	± 3°C (excluding thermocouple error)

Voltage Specifications

Voltage Ranges	Voltage: 0-5V, ±5V, 0-156.25mV, ± 156.25mVDC
Resolution	16 bit (1 in 65535)
Full Scale Calibration Error (Offset Error Included)	± 13 counts typical, ± 33 maximum
Offset Calibration Error	± 1 count maximum, @ 0V input
Linearity Error (End to End)	± 1 count maximum
Maximum Inaccuracy	± .02% @ 25°C (77°F)

Module Calibration

The F2-04THM module requires no calibration. The module automatically calibrates every five seconds, which removes offset and gain errors. For each thermocouple type, the temperature calculation and linearization performed by the microprocessor is accurate to within .01 °C.

Thermocouple Input Configuration Requirements

The F2-04THM module requires 32 discrete input points from the CPU. The module can be installed in any slot of a DL205 system. The limitations on the number of analog modules are:

- For local and local expansion systems, the available power budget and number of discrete I/O points.
- For remote I/O systems, the available power budget and number of remote I/O points.

Check the user manual for your particular model of CPU and I/O base for more information regarding power budget and number of local, local expansion or remote I/O points.

Special Placement Requirements (DL230 and Remote I/O Bases)

It is important to examine the configuration if you are using a DL230 CPU. As you can see in the section on writing the program, you use V-memory locations to send the analog data. If you place the module so that the input points do not start on a V-memory boundary, the instructions cannot access the data. This also applies when placing this module in a remote base using a D2-RSSS in the CPU slot.

Correct!

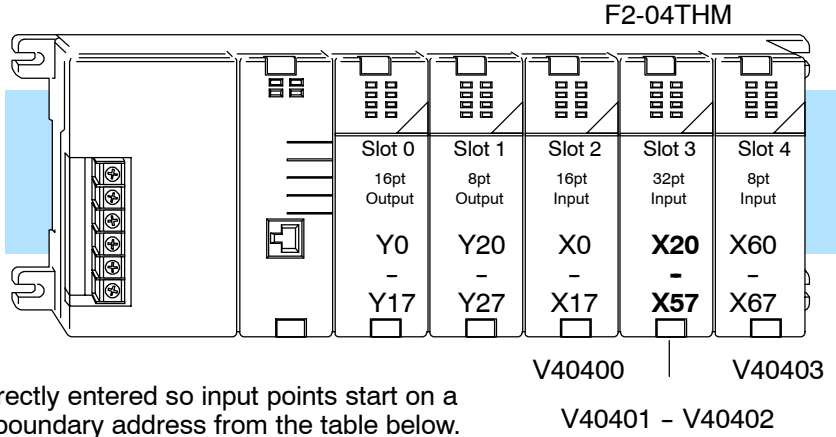

V40402			V40401		
MSB		LSB	MSB		LSB
X	X X	X	X	X X	X
5	5 4	4	3	3 2	2
7	0 7	0	7	0 7	0

Incorrect

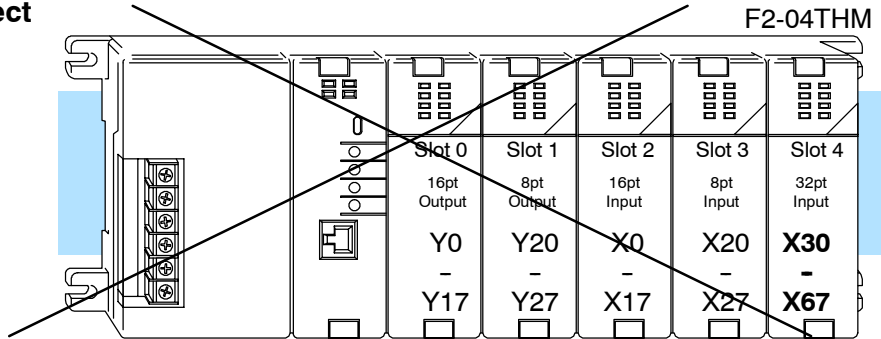

Data is split over three locations, so instructions cannot access data from a DL230.

V40403			V40402			V40401		
MSB		LSB	MSB		LSB	MSB		LSB
X	X X	X	X	X X	X	X	X X	X
7	7 6	6	5	5 4	4	3	3 2	2
7	0 7	0	7	0 7	0	7	0 7	0

To use the V-memory references required for a DL230 CPU, the *first* input address assigned to the module must be one of the following X locations. The table also shows the V-memory addresses that correspond to these X locations.

X	X0	X20	X40	X60	X100	X120	X140	X160
V	V40400	V40401	V40402	V40403	V40404	V40405	V40406	V40407

Setting the Module Jumpers

Jumper Locations

Use the figures below to locate the single jumper (J9) and bank of eight jumpers (J7) on the PC board. Notice that the PC board was re-designed starting with date code 0806E1 and the jumper locations changed; the functionality of the jumpers did not change. To prevent losing a jumper when it is removed, store it in its original location by sliding one of its sockets over a single pin. You can select the following options by installing or removing the appropriate jumpers:

- Number of channels
- Input type
- Conversion units
- Calibrate enable

Jumper Locations on Modules Having Date Code Prior to 0806E1

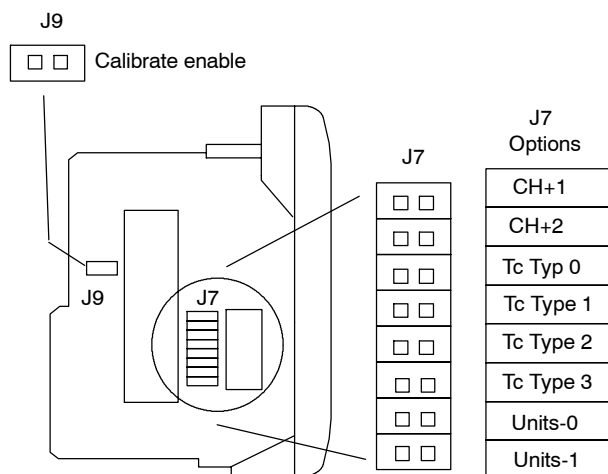

Jumper Locations on Modules Having Date Code 0806E1 and Later

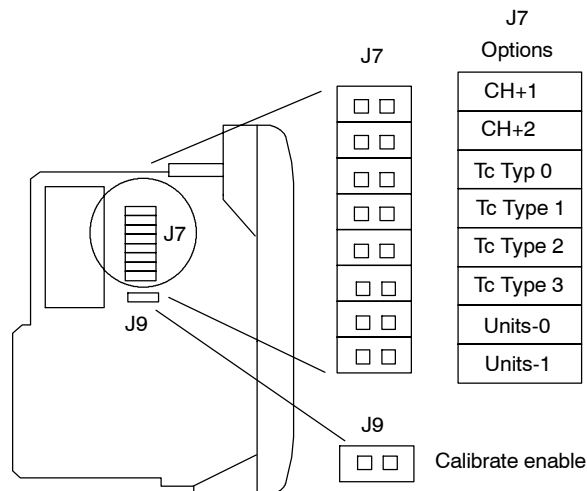

Calibrate Enable

Locate the "Calibrate Enable" jumper J9. The jumper comes from the factory in the "jumper removed" setting (the jumper is installed over only one of the two pins). Installing this jumper disables the thermocouple active burn-out detection circuitry, which enables you to attach a thermocouple calibrator to the module.

To make sure that the output of the thermocouple calibrator is within the 5V common mode voltage range of the module, connect the negative side of the differential voltage input channel to the 0V terminal, then connect the thermocouple calibrator to the differential inputs (for example, Ch 3+ and Ch 3).

For the voltage input ranges, this jumper is inactive and can be installed or removed with no effect on voltage input.

Selecting the Number of Channels

The top two J7 jumpers labeled **CH+1** and **CH+2** determine the number of channels that will be used. The table shows how to set the jumpers for channels 1 thru 4. The module comes with both jumpers installed for four channel operation. For example, to select channels 1 thru 3, leave the CH+2 jumper installed and remove the CH+1 jumper. Any unused channels are not processed. For example, if you only select channels 1 thru 3, channel 4 will not be active.

X = jumper installed,
blank space = jumper removed

Number of Channels	Jumper	
	CH+1	CH+2
1		
2	X	
3		X
4	X	X

Setting Input Type

The next four jumpers (**Tc Type 0**, **Tc Type 1**, **Tc Type 2**, **Tc Type 3**) must be set to match the type of thermocouple being used or the input voltage level. The module can be used with many types of thermocouples. Use the table to determine your settings.

The module comes from the factory with all four jumpers installed for use with a J type thermocouple. For example, to use an S type thermocouple, remove the jumper labeled Tc Type 2. All channels of the module must be the same thermocouple type or voltage range.

X = Jumper installed, and blank space = jumper removed.

Thermocouple / Voltage Inputs	Jumper			
	Tc Type 0	Tc Type 1	Tc Type 2	Tc Type 3
J	X	X	X	X
K		X	X	X
E	X		X	X
R			X	X
S	X	X		X
T		X		X
B	X			X
N				X
C	X	X	X	
0-5V.		X	X	
±5V.	X		X	
0-156mV.			X	
±156mV.	X	X		

Selecting the Conversion Units

Use the last two jumpers, **Units-0** and **Units-1**, to set the conversion unit used for either thermocouples or voltage inputs. The options are magnitude plus sign or 2's complement, plus Fahrenheit or Celsius for thermocouples. See the next two sections for jumper settings when using thermocouples or if using voltage inputs.

Thermocouple Conversion Units

All thermocouple types are converted into a direct temperature reading in either Fahrenheit or Celsius. The data contains one implied decimal place. For example, a value in V-memory of 1002 would be 100.2°C or °F.

For thermocouple ranges which include negative temperatures (J,E,K,T,N), the display resolution is from -3276.7 to +3276.7. For positive-only thermocouple ranges (R,S,B,C), the display resolution is 0 to 6553.5.

Negative temperatures can be represented in either 2's complement or magnitude plus sign form. If the temperature is negative, the most significant bit in the V-memory location is set (X17).

The 2's complement data format may be required to correctly display bipolar data on some operator interfaces. This data format could also be used to simplify averaging a bipolar signal. To view this data format in **DirectSoft32**, select Signed Decimal.

For unipolar thermocouple ranges (R,S,B,C), it does not matter if magnitude plus sign or 2's complement is selected.

Use the table to select settings. The module comes with both jumpers installed for magnitude plus sign conversion in Fahrenheit. For example, remove the Units-0 jumper and leave the Units-1 jumper installed for magnitude plus sign conversion in Celsius.

X = Jumper installed, and blank space = jumper removed.

Jumper	Temperature Conversion Units			
	Magnitude Plus Sign		2's Complement	
	°F	°C	°F	°C
Units-0	X		X	
Units-1	X	X		

Voltage Conversion Units

The bipolar voltage input ranges, $\pm 5V$ or $\pm 156mV$ (see previous page for $\pm 5V$ and $\pm 156mV$ settings), may be converted to a 15-bit magnitude plus sign or a 16-bit 2's complement value.

Use the table to select settings. The module comes with both jumpers installed for magnitude plus sign conversion. Remove the Units-1 jumper and leave the Units-0 jumper installed for 2's complement conversion.

X = Jumper installed, and blank space = jumper removed.

Jumper Pins	Voltage Conversion Units	
	Magnitude Plus Sign	2's Complement
Units-0	X	X
Units-1	X	

Connecting the Field Wiring

Wiring Guidelines

Your company may have guidelines for wiring and cable installation. If so, you should check those before you begin the installation. Here are some general things to consider:

- Use the shortest wiring route whenever possible.
- Use shielded wiring and ground the shield at the transmitter source. *Do not* ground the shield at both the module and the source.
- Do not run the signal wiring next to large motors, high current switches, or transformers. This may cause noise problems.
- Route the wiring through an approved cable housing to minimize the risk of accidental damage. Check local and national codes to choose the correct method for your application.

User Power Supply Requirements

You may use the same or separate power source for the 0-5V or 0-156mV transmitter voltage supply. The DL205 bases have built-in 24 VDC power supplies that provide up to 300mA of current. You may use this instead of a separate supply if you are using only a couple of analog modules and voltage transmitters.

It is desirable in some situations to power the transmitters separately in a location remote from the PLC. This will work as long as the transmitter supply meets the voltage and current requirements and the transmitter's minus (-) side and the module supply's minus (-) side are connected together.



WARNING: If you are using the 24 VDC base power supply, make sure you calculate the power budget. Exceeding the power budget can cause unpredictable system operation that can lead to a risk of personal injury or damage to equipment.

The DL205 base has a switching type power supply. As a result of switching noise, you may notice some instability in the analog input data if you use the base power supply. If this is unacceptable, you should try one of the following:

1. Use a separate linear power supply.
2. Connect the 24VDC common to the frame ground, which is the screw terminal marked "G" on the base.

Unused temperature inputs should be shorted together and connected to common.

Thermocouples

Use shielded thermocouples whenever possible to minimize the presence of noise on the thermocouple wire. Ground the shield wire at one end only. For grounded thermocouples, connect the shield at the sensor end. For ungrounded thermocouples, connect the shield to the 0V (common) terminal.

Grounded Thermocouple Assembly

A grounded thermocouple provides better response time than an ungrounded thermocouple because the tip of the thermocouple junction is in direct contact with the protective case.

Ungrounded Thermocouple Assembly

An ungrounded thermocouple is electrically isolated from the protective case. If the case is electrically grounded it provides a low-impedance path for electrical noise to travel. The ungrounded thermocouple provides a more stable and accurate measurement in a noisy environment.

Exposed Grounded Thermocouple

The thermocouple does not have a protective case and is directly connected to a device with a higher potential. Grounding the thermocouple assures that the thermocouple remains within the common mode specifications. Because a thermocouple is essentially a wire, it provides a low-impedance path for electrical noise. The noise filter has a response of $>100\text{dB @ }50/60\text{ Hz}$.

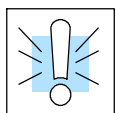

WARNING: A thermocouple can become shorted to a high voltage potential. Because common terminals are internally connected together, whatever voltage potential exists on one thermocouple will exist on the other channels.

Ambient Variations in Temperature

The F2-04THM module has been designed to operate within the ambient temperature range of 0°C to 60°C .

The cold junction compensation is calibrated to operate in a still-air environment. If the module is used in an application that has forced convection cooling, an error of $2\text{--}3^{\circ}\text{C}$ may be introduced. To compensate for this you can use ladder logic to correct the values.

When configuring the system design it is best to locate any heat-producing devices above and away from the PLC chassis because the heat will affect the temperature readings. For example, heat introduced at one end of the terminal block can cause a channel-to-channel variation.

When exposing the F2-04THM module to abrupt ambient temperature changes it will take several minutes for the cold junction compensation and terminal block to stabilize. Errors introduced by abrupt ambient temperature changes will be less than 4°C .

Wiring Diagram

Use the following diagrams to connect the field wiring.

Thermocouple Input Wiring Diagram

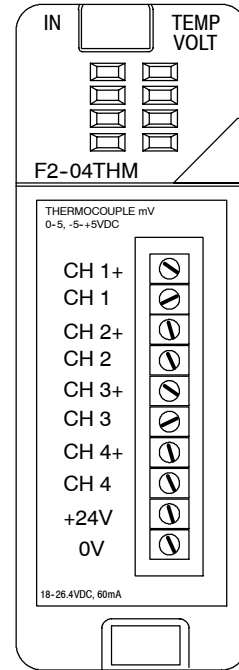
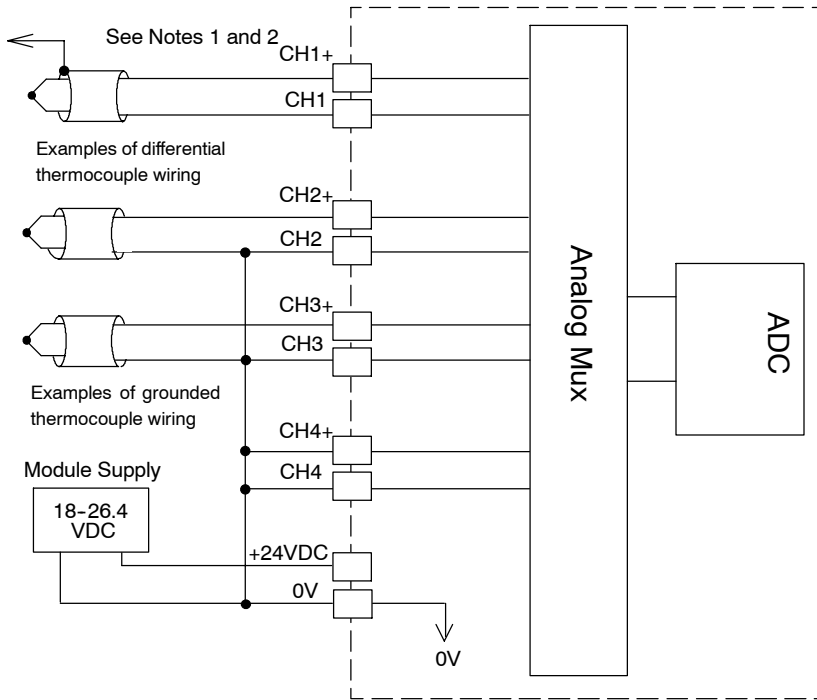

Note 1: Terminate shields at the respective signal source.
 Note 2: Connect unused channels to a common terminal (0V, CH4+, CH4).

Voltage Input Wiring Diagram

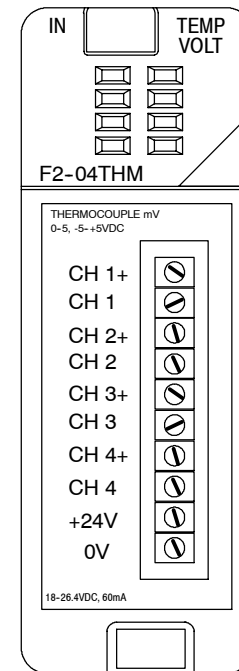
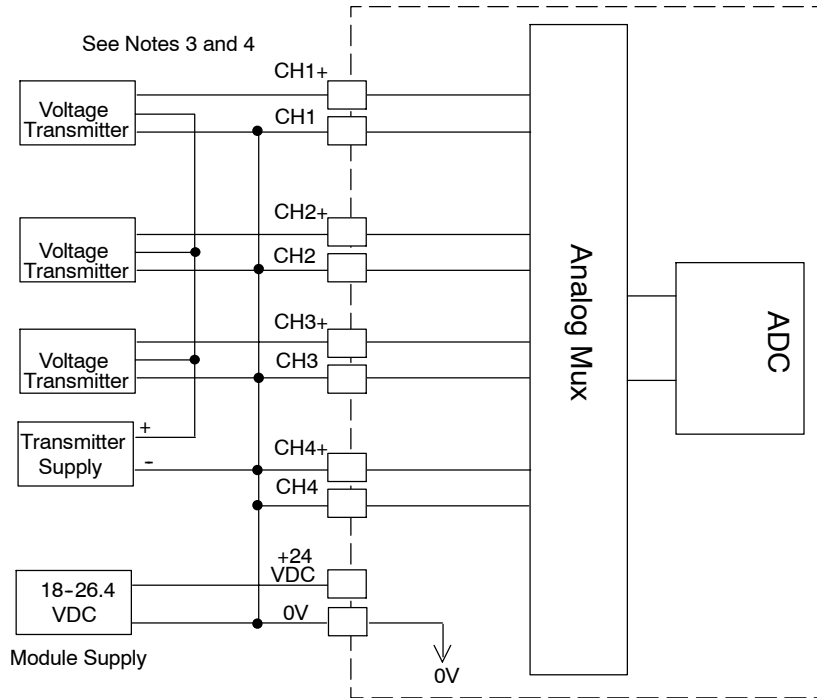

Note 3: Connect unused channels to a common terminal (0V, CH4+, CH4).
 Note 4: When using 0-156mV and 5V ranges, connect (-) or (0) volts terminals (CH1, CH2, CH3, CH4, CH+4) to 0V to ensure common mode range acceptance.

Module Operation

Channel Scanning Sequence for a DL230 CPU (Multiplexing)

Before you begin writing the control program, it is important to take a few minutes to understand how the module processes and represents the analog signals.

The F2-04THM module can supply different amounts of data per scan, depending on the type of CPU you are using. The DL230 can obtain one channel of data per CPU scan. Since there are four channels, it can take up to four scans to get data for all channels. Once all channels have been scanned the process starts over with channel 1. Unused channels are not processed, so if you select only two channels, then each channel will be updated every other scan. The multiplexing method can also be used for the DL240/250-1/260 CPUs.

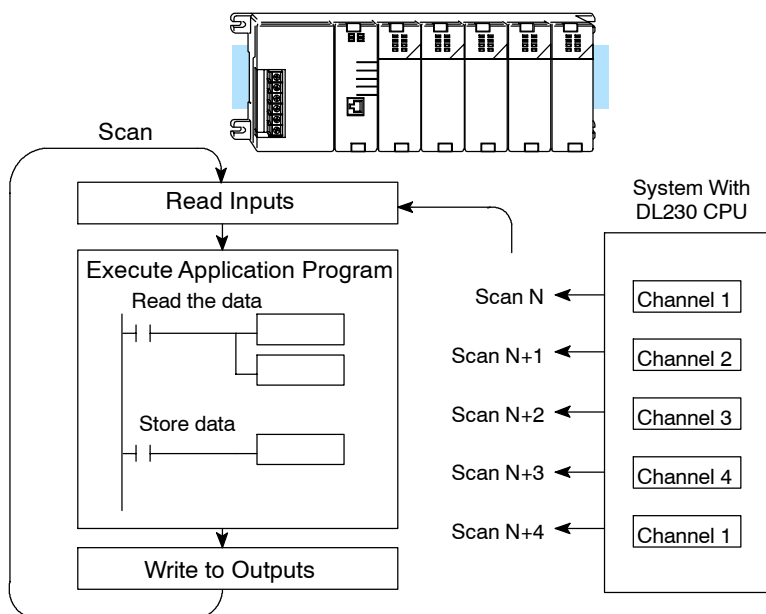

Channel Scanning Sequence for a DL240, DL250-1 or DL260 CPU (Pointer Method)

If you are using a DL240, DL250-1 or a DL260 CPU, you can obtain all four channels of input data in one scan. This is because the DL240/250-1/260 CPUs support special V-memory locations that are used to manage the data transfer (this is discussed in more detail in the section on Writing the Control Program).

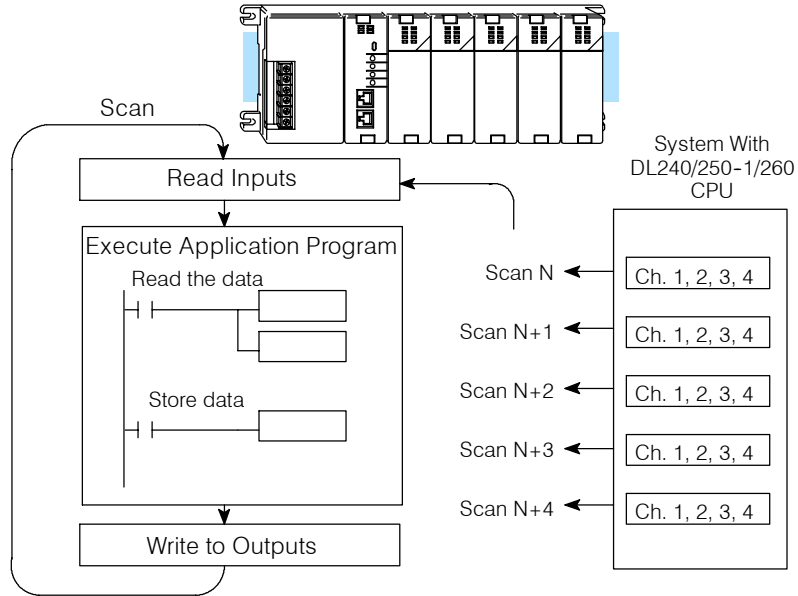

Analog Module Updates

Even though the channel updates to the CPU are synchronous with the CPU scan, the module asynchronously monitors the analog transmitter signal and converts the signal to a 16-bit binary representation. This enables the module to continuously provide accurate measurements without slowing down the discrete control logic in the RLL program.

The time required to sense the temperature and copy the value to V-memory is 160 milliseconds minimum to 640 milliseconds plus 1 scan time maximum (number of channels x 160 milliseconds + 1 scan time).

F2-04THM
4-Ch. Thermocouple

Writing the Control Program

Reading Values: Pointer Method and Multiplexing

There are two methods of reading values:

- The pointer method
- Multiplexing

You *must* use the multiplexing method when using a DL230 CPU. You must also use the multiplexing method with remote I/O modules (the pointer method will not work). You can use either method when using DL240, DL250-1 and DL260 CPUs, but for ease of programming it is strongly recommended that you use the pointer method.

The CPU has special V-memory locations assigned to each base slot that greatly simplify the programming requirements. These V-memory locations:

- specify the number of channels to scan.
- specify the storage locations.

The example program shows how to setup these locations. Place this rung anywhere in the ladder program, or in the initial stage if you are using stage programming instructions. This is all that is required to read the data into V-memory locations. Once the data is in V-memory, you can perform math on the data, compare the data against preset values, and so forth. V2000 is used in the example, but you can use any user V-memory location. In the examples, the module is installed in slot 2. You should enter the V-memory locations used in your application. The pointer method automatically converts values to BCD.

Pointer Method

✗	✓	✓	✓
230	240	250-1	260

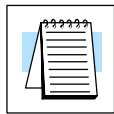

NOTE: DL240 CPUs with firmware release version 2.5 or later and DL250 CPUs with firmware release version 1.06 or later support this method. Use the DL230 multiplexing example if your firmware revision is earlier.

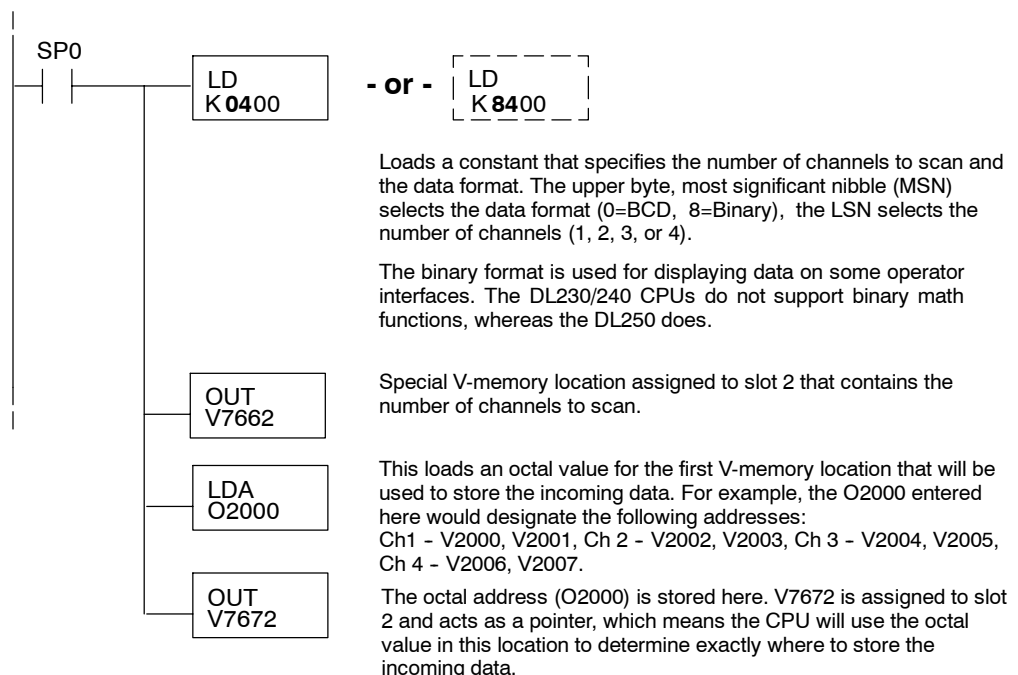

The tables below show the special V-memory locations used by the DL240, DL250-1 and DL260 for the CPU base and local expansion base I/O slots. Slot 0 (zero) is the module next to the CPU or D2-CM module. Slot 1 is the module two places from the CPU or D2-CM, and so on. Remember, the CPU only examines the pointer values at these locations after a mode transition. Also, if you use the DL230 (multiplexing) method, verify that these addresses in the CPU are zero.

The Table below applies to the DL240, DL250-1 and DL260 CPU base.

CPU Base: Analog Input Module Slot-Dependent V-memory Locations								
Slot	0	1	2	3	4	5	6	7
No. of Channels	V7660	V7661	V7662	V7663	V7664	V7665	V7666	V7667
Storage Pointer	V7670	V7671	V7672	V7673	V7674	V7675	V7676	V7677

The Table below applies to the DL250-1 or DL260 expansion base 1.

Expansion Base D2-CM #1: Analog Input Module Slot-Dependent V-memory Locations								
Slot	0	1	2	3	4	5	6	7
No. of Channels	V36000	V36001	V36002	V36003	V36004	V36005	V36006	V36007
Storage Pointer	V36010	V36011	V36012	V36013	V36014	V36015	V36016	V36017

The Table below applies to the DL250-1 or DL260 expansion base 2.

Expansion Base D2-CM #2: Analog Input Module Slot-Dependent V-memory Locations								
Slot	0	1	2	3	4	5	6	7
No. of Channels	V36100	V36101	V36102	V36103	V36104	V36105	V36106	V36107
Storage Pointer	V36110	V36111	V36112	V36113	V36114	V36115	V36116	V36117

The Table below applies to the DL260 CPU expansion base 3.

Expansion Base D2-CM #3: Analog Input Module Slot-Dependent V-memory Locations								
Slot	0	1	2	3	4	5	6	7
No. of Channels	V36200	V36201	V36202	V36203	V36204	V36205	V36206	V36207
Storage Pointer	V36210	V36211	V36212	V36213	V36214	V36215	V36216	V36217

The Table below applies to the DL260 CPU expansion base 4.

Expansion Base D2-CM #4: Analog Input Module Slot-Dependent V-memory Locations								
Slot	0	1	2	3	4	5	6	7
No. of Channels	V36300	V36301	V36302	V36303	V36304	V36305	V36306	V36307
Storage Pointer	V36310	V36311	V36312	V36313	V36314	V36315	V36316	V36317

Negative Temperature Readings with Magnitude Plus Sign (Pointer Method)

✗	✓	✓	✓
230	240	250-1	260



With bipolar ranges, you need some additional logic to determine whether the value being returned represents a positive voltage or a negative voltage. For example, you may need to know the direction for a motor. There is a simple solution:

- If you are using bipolar ranges and you get a value greater than or equal to 8000_H, the value is negative.
- If you get a value less than or equal to 7FFF_H, the value is positive.

The sign bit is the most significant bit, which combines 8000_H to the data value. If the value is greater than or equal to 8000_H, you only have to mask the most significant bit and the active channel bits to determine the actual data value.

NOTE: DL240 CPUs with firmware release version 2.5 or later and DL250 CPUs with firmware release version 1.06 or later support this method. Use the DL230 multiplexing example if your firmware revision is earlier.

The following two programs show how you can accomplish this. The first example uses magnitude plus sign (binary) and the second example uses magnitude plus sign (BCD).

Since you always want to know when a value is negative, these rungs should be placed *before* any other operations that use the data, such as math instructions, scaling operations, and so forth. Also, if you are using stage programming instructions, these rungs should be in a stage that is always active. Note: you only need this logic for each channel that is using bipolar input signals. The examples only show two channels.

Magnitude Plus Sign (Binary)

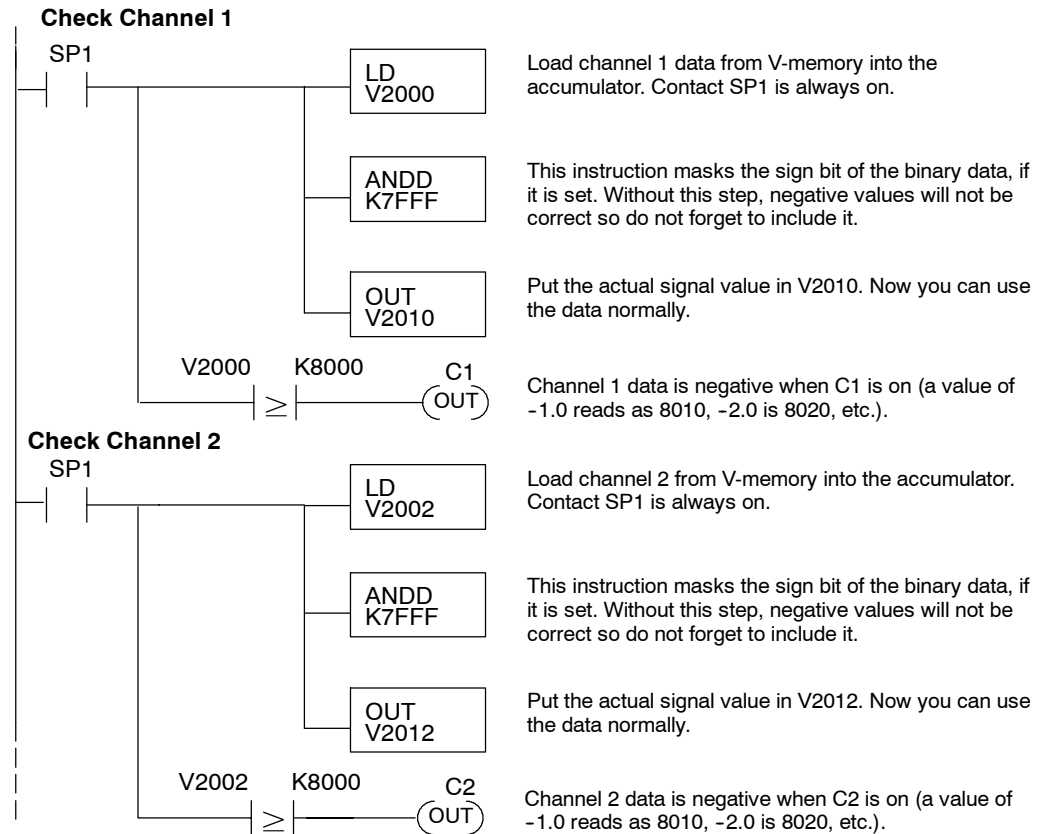

Magnitude Plus Sign (BCD)

F2-04THM
4-Ch. Thermocouple

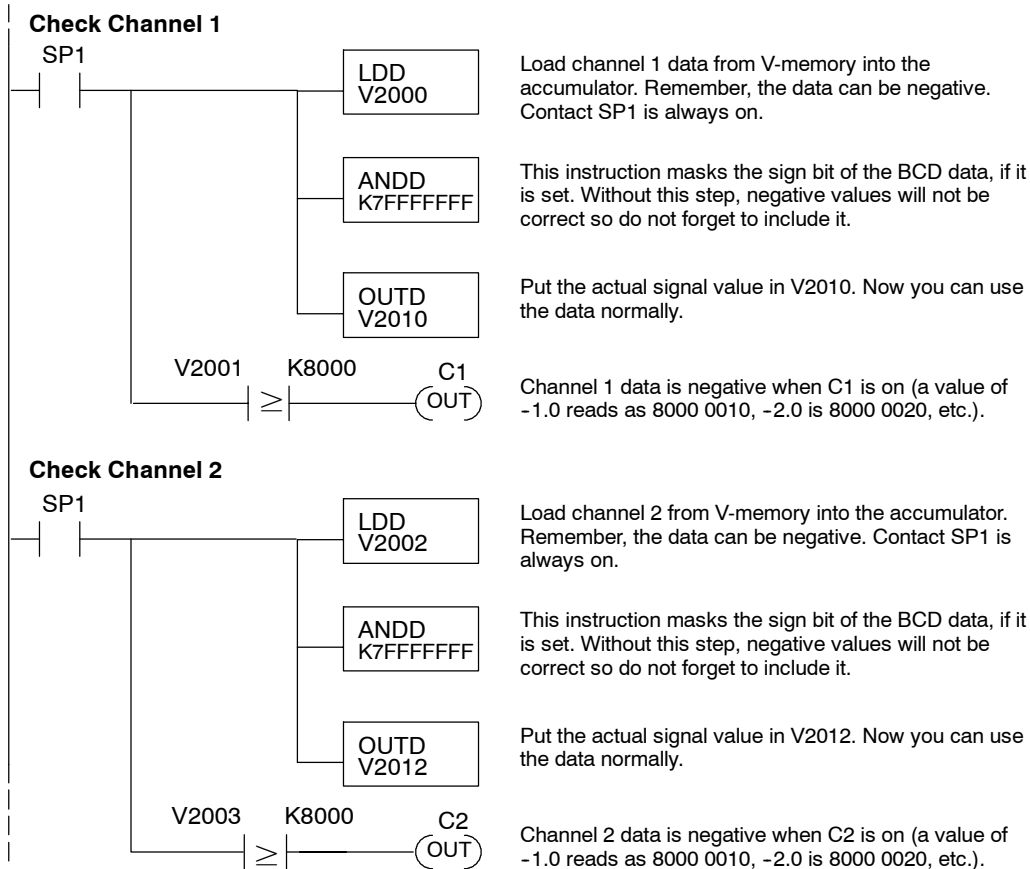

Negative Temperatures 2's Complement (Binary / Pointer Method)



x

You can use the 2's complement mode for negative temperature display purposes while at the same time using the magnitude plus sign of the temperature in your control program. The *DirectSOFT32* element Signed Decimal is used to display negative numbers in 2's complement form. To find the absolute value of a negative number in 2's complement, invert the number and increment it by 1 as shown in the following example:

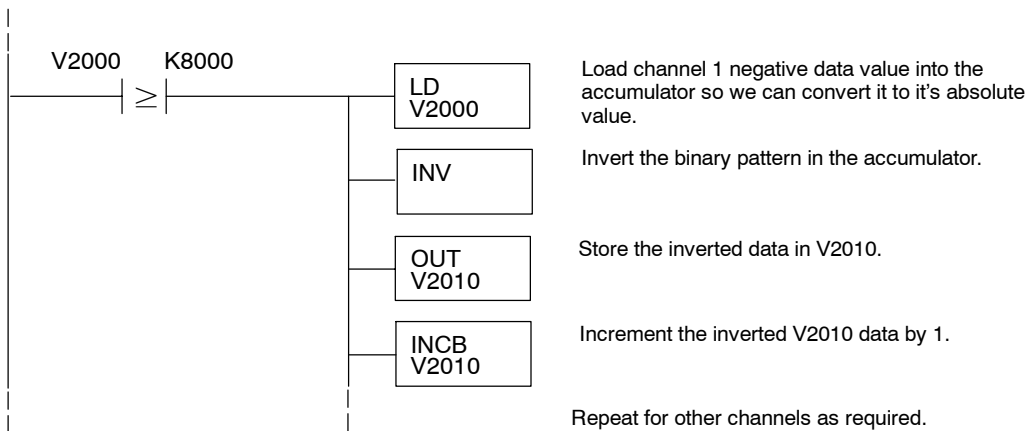

Understanding the Input Assignments (Multiplexing Ladder Only)



You may recall that the F2-04THM module appears to the CPU as a 32-point discrete input module. You can use these points to obtain:

- An indication of which channel is active
- The digital representation of the analog signal
- Module diagnostic information

Since all input points are automatically mapped into V-memory, it is very easy to determine the location of the data word that will be assigned to the module.

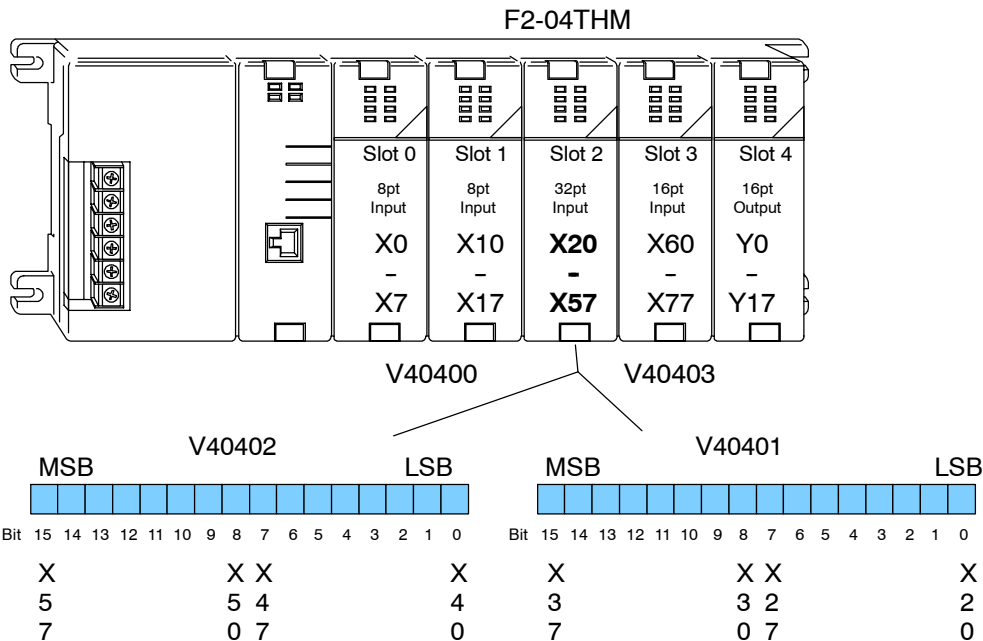

F2-04THM
4 Ch. Thermocouple

Remember, when using DL230 CPUs input points must start on a V-memory boundary. To use the V-memory references required for a DL230 CPU, the *first* input address assigned to the module must be one of the following X locations. The table also shows the V-memory addresses that correspond to these X locations.

X	X0	X20	X40	X60	X100	X120	X140	X160
V	V40400	V40401	V40402	V40403	V40404	V40405	V40406	V40407

Analog Data Bits

The first 16 bits represent the analog data in binary format.

Bit	Value	Bit	Value
0	1	8	256
1	2	9	512
2	4	10	1024
3	8	11	2048
4	16	12	4096
5	32	13	8192
6	64	14	16384
7	128	15	32768

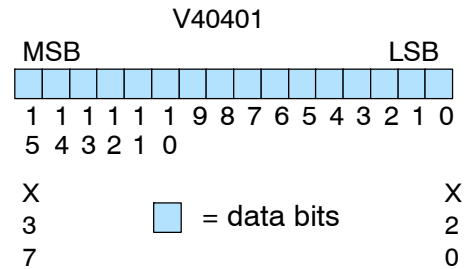

Active Channel Bits

The active channel bits represent the multiplexed channel selections in binary format.

Bit 1	Bit 0	Channel
0	0	1
0	1	2
1	0	3
1	1	4

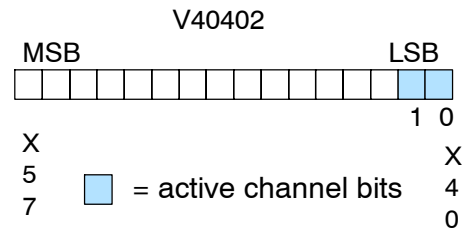

Broken Transmitter Bits (Pointer and Multiplexing Ladder Methods)

The broken transmitter bits are on when the corresponding thermocouple is open.

Bit	Channel
8	1
9	2
10	3
11	4

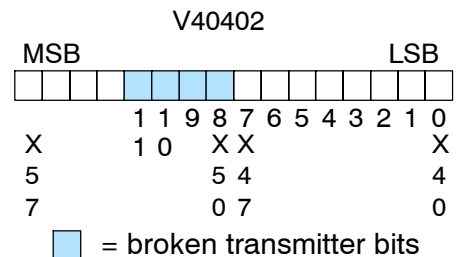

**Reading
Magnitude Plus
Sign Values
(Multiplexing)**

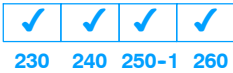

The DL230 CPU *does not* have the special V-memory locations that allow you to automatically enable the data transfer. Since all channels are multiplexed into a single data word, the control program must be setup to determine which channel is being read. Since the module appears as X input points to the CPU, it is very easy to use the active channel status bits to determine which channel is being monitored.

NOTE: DL230 CPUs with firmware release version 1.6 or later is required for multiplexing ladder.

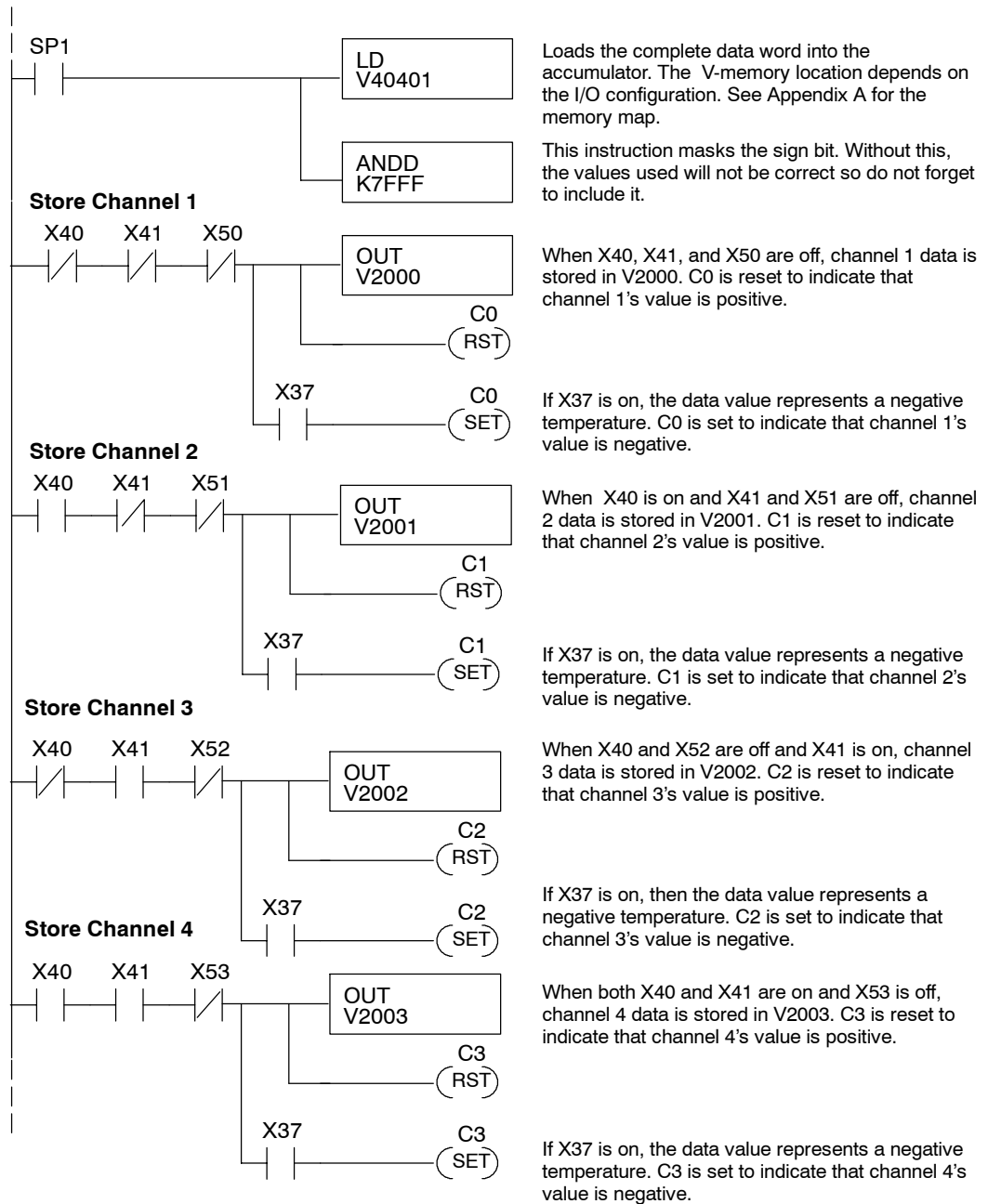

Reading 2's Complement Values (Multiplexing)



230 240 250-1 260

The DL230 CPU *does not* have the special V-memory locations that allow you to automatically enable the data transfer. Since all channels are multiplexed into a single data word, the control program must be setup to determine which channel is being read. Since the module appears as X input points to the CPU, it is very easy to use the active channel status bits to determine which channel is being monitored. The 2's complement data format may be required to correctly display bipolar data on some operator interfaces. This data format could also be used to simplify averaging a bipolar signal. To view this data format in **DirectSOFT32**, select Signed Decimal.

Load Data

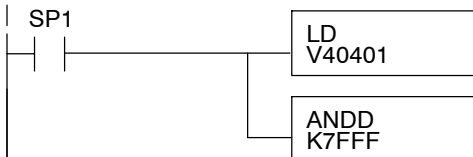

Loads the complete data word into the accumulator. The V-memory location depends on the I/O configuration.

This instruction masks the channel sign bit.

Store Channel 1

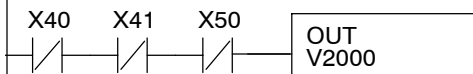

When X40, X41 and X50 are off, channel 1 data is stored in V2000.

Store Channel 2

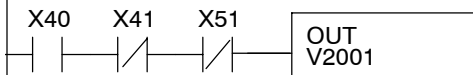

When X40 is on and X41 and X51 are off, channel 2 data is stored in V2001.

Store Channel 3

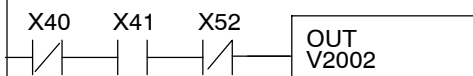

When X40 and X52 are off and X41 is on, channel 3 data is stored in V2002.

Store Channel 4

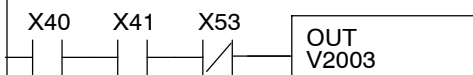

When both X40 and X41 are on and X53 is off, channel 4 data is stored in V2003.

Scaling the Input Data

No scaling of the input temperature is required. The readings directly reflect the actual temperatures. For example: a reading of 8482 is 848.2 °C, a reading of 16386 is -0.2°C. (magnitude plus sign), and a reading of 32770 is -0.2°C (2's complement).

**Module Resolution
16-Bit (Unipolar
Voltage Input)**

Unipolar analog signals are converted into 65536 counts ranging from 0 to 65535 (2^{16}). For example, with a 0 to 156mV signal range, 78mV would be 32767. A value of 65535 represents the upper limit of the range.

$$\text{Unipolar Resolution} = \frac{H - L}{65535}$$

H or L = high or low limit of the range

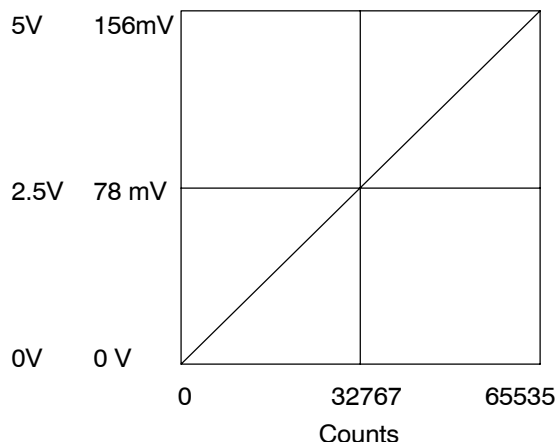
**Module Resolution
15-Bit Plus Sign
(Bipolar Voltage
Input)**

The module has 16-bit unipolar or 15-bit + sign bipolar resolution. Bipolar analog signals are converted into 32768 counts ranging from 0 to 32767 (2^{15}). For example, with a -156mV to 156mV signal range, 156mV would be 32767. The bipolar ranges utilize a sign bit to provide 16-bit resolution. A value of 32767 can represent the upper limit of either side of the range. Use the sign bit to determine negative values.

$$\text{Bipolar Resolution} = \frac{H - L}{32767}$$

H or L = high or low limit of the range

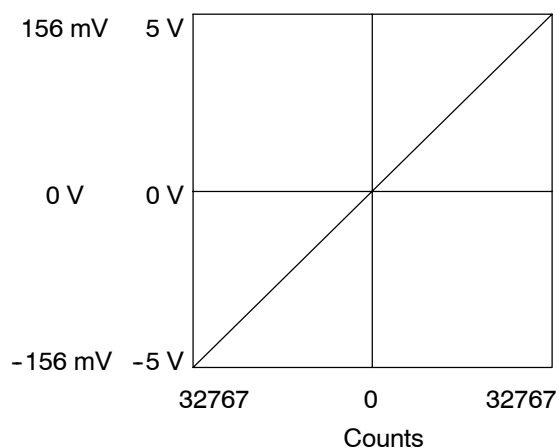

Analog and Digital Value Conversions

Sometimes it is useful to be able to quickly convert between the signal levels and the digital values. This is especially helpful during machine startup or troubleshooting. Remember, this module *does not* operate like other versions of analog input modules that you may be familiar with. The bipolar ranges use 0-32767 for both positive and negative voltages. The sign bit allows this and it actually provides better resolution than those modules that do not offer a sign bit. The following table provides formulas to make this conversion easier.

Range	If you know the digital value ...	If you know the signal level ...
0 to 5V	$A = \frac{5D}{65535}$	$D = \frac{65535}{5} (A)$
0 to 156.25mV	$A = \frac{0.15625D}{65535}$	$D = \frac{65535}{0.15625} (A)$
±5V	$A = \frac{10D}{65535}$	$D = \frac{65535}{10} (A)$
±156.25mV	$A = \frac{0.3125D}{65535}$	$D = \frac{65535}{0.3125} (A)$

For example, if you are using the ±5V range and you have measured the signal at 2.5V, use the following formula to determine the digital value that is stored in the V-memory location that contains the data.

$$D = \frac{65535}{10} (A)$$

$$D = \frac{65535}{10} (2.5V)$$

$$D = (6553.5) (2.5)$$

$$D = 16383.75$$

Filtering Input Noise (DL250-1, DL260 CPUs Only)

X	X	✓	✓
230	240	250-1	260



Add the following logic to filter and smooth analog input noise in DL250-1 and DL260 CPUs. This is especially useful when using PID loops. Noise can be generated by the field device and/or induced by field wiring.

The analog value in BCD is first converted to a binary number because there is not a BCD-to-real conversion instruction. Memory location V1400 is the designated workspace in this example. The MULR instruction is the filter factor, which can be from 0.1 to 0.9. The example uses 0.2. A smaller filter factor increases filtering. You can use a higher precision value, but it is not generally needed. The filtered value is then converted back to binary and then to BCD. The filtered value is stored in location V1402 for use in your application or PID loop.

NOTE: Be careful not to do a multiple number conversion on a value. For example, if you are using the pointer method to get the analog value, it is in BCD and must be converted to binary. However, if you are using the conventional method of reading analog and are masking the first fifteen bits, then it is already in binary and no conversion using the BIN instruction is needed. Also, if you are using the conventional method, change the LDD V2000 instruction to LD V2000.

