

F0-2AD2DA-2 2-Ch. IN/2-Ch. OUT ANALOG VOLTAGE COMBINATION



In This Chapter...

Module Specifications6-2
Setting the Module Jumpers6-4
Connecting and Disconnecting the Field Wiring6-5
Wiring Diagram6-5
Module Operation6-6
Special V-memory Locations6-7
Using the Pointer in Your Control Program6-10
Scale Conversions6-12
Module Resolution6-15
Analog Input Ladder Logic Filter6-16

Module Specifications

The F0-2AD2DA-2 Analog Combination module offers the following features: The analog input and output channels are updated in one scan.

- The module has a removable terminal block which makes it possible to remove the module without disconnecting the field wiring.
- Analog inputs can be used as process variables for the four (4) PID loops in the DL05 and the eight (8) PID loops in the DL06 CPUs.
- On-board active analog filtering and RISC-like microcontroller provide digital signal processing to maintain precise analog measurements in noisy environments.

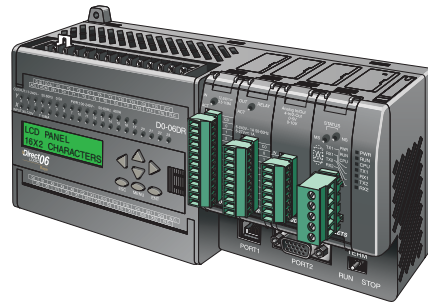

NOTE: The DL05 CPU's analog feature for this module requires **DirectSOFT32** Version 3.0c (or later) and firmware version 3.30 (or later). The DL06 requires **DirectSOFT32** version V4.0, build 16 (or later) and firmware version 1.00 (or later). See our website for more information: www.automationdirect.com.

The following tables provide the specifications for the F0-2AD2DA-2 Analog Voltage Combination Module. Review these specifications to make sure the module meets your application requirements.

Input Specifications	
Number of Channels	2, single ended (one common)
Input Range	0 to 5 VDC or 0 to 10 VDC (jumper selectable)
Resolution	12 bit (1 in 4096)
Step Response	10.0 mS to 95% of full step change
Crosstalk	1/2 count maximum (-80db)*
Active Low-pass Filtering	-3 dB at 300Hz (-12 dB per octave)
Input Impedance	Greater than 20K Ω
Absolute Maximum Ratings	$\pm 15V$
Linearity Error (End to End)	± 2 counts (0.025% of full scale) maximum*
Input Stability	± 1 count *
Gain Error	± 6 counts *
Offset Error	± 2 counts *
Maximum Inaccuracy	0.3% @ 25°C (77°F) 0.6% 0 to 60°C (32 to 140°F)
Accuracy vs. Temperature	± 100 ppm/°C typical

Output Specifications	
Number of Channels	2, single ended (one common)
Output Range	0 to 5 VDC or 0 to 10 VDC (jumper selectable)
Resolution	12 bit (1 in 4096)
Conversion Settling Time	50 μ S for full scale change
Crosstalk	1/2 count maximum (-80db) *
Peak Output Voltage	± 15 VDC (power supply limited)
Offset Error	0.1% of range
Gain Error	0.4% of range
Linearity Error (end to end)	± 1 count (0.075% of full scale) maximum*
Output Stability	± 2 counts*
Load Impedance	2K Ω minimum
Load Capacitance	0.01 μ F maximum
Accuracy vs. Temperature	± 50 ppm/°C typical

* One count in the specification table is equal to one least significant bit of the analog data value (1 in 4096).

General Specifications	
PLC Update Rate	2 input channels per scan 2 output channels per scan
16-bit Data Word	12 binary data bits
Operating Temperature	0 to 60° C (32 to 140° F)
Storage Temperature	-20 to 70° C (-4 to 158° F)
Relative Humidity	5 to 95% (non-condensing)
Environmental Air	No corrosive gases permitted
Vibration	MIL STD 810C 514.2
Shock	MIL STD 810C 516.2
Noise Immunity	NEMA ICS3-304
Power Budget Requirement	50 mA @ 5 VDC (supplied by base)
External Power Supply	30 mA, 24 VDC ±10%
Connector	Phoenix Mecano, Inc. Part No. AK1550/8-3.5 - green
Connector Wire Size	28 - 16 AWG
Connector Screw Torque	0.4 Nm
Connector Screwdriver Size	DN-SS1 (recommended)

6

Setting the Module Jumpers

The position of the J2 jumpers determines the input and output signal levels. You can choose between 0–5 VDC or 0–10 VDC. The module ships with the jumpers connecting the pins. In this position, the input and output signal level is 0–5 VDC. To select 0–10 VDC signals, use the jumper setting chart located on the module. One or more channels can be selected for 0–10 VDC input and output signal level by removing the jumper from the connecting pins of the appropriate channel. This will allow you to have one channel selected for a 0–5 VDC signal and another channel selected for a 0–10 VDC signal.

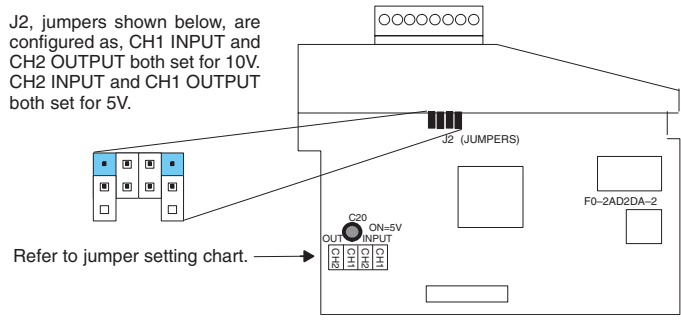

WARNING: Before removing the analog module or the terminal block on the face of the module, disconnect power to the PLC and all field devices. Failure to disconnect power can result in damage to the PLC and/or field devices.

Connecting and Disconnecting the Field Wiring

Wiring Guidelines

Your company may have guidelines for wiring and cable installation. If so, you should check those before you begin the installation. Here are some general things to consider:

- Use the shortest wiring route whenever possible.
- Use shielded wiring and ground the shield at the transmitter source. *Do not* ground the shield at both the module and the source.
- Do not run the signal wiring next to large motors, high current switches, or transformers. This may cause noise problems.
- Route the wiring through an approved cable housing to minimize the risk of accidental damage. Check local and national codes to choose the correct method for your application.

The F0-2AD2DA-2 will require an external power supply with a rating of 18.0–26.4VDC at 30 mA.

To remove the terminal block, disconnect power to the PLC and the field devices. Pull the terminal block firmly until the connector separates from the module.

You can remove the analog module from the PLC by folding out the retaining tabs at the top and bottom of the module. As the retaining tabs pivot upward and outward, the module's connector is lifted out of the PLC socket. Once the connector is free, you can lift the module out of its slot.

Wiring Diagram

Use the following diagram to connect the field wiring. If necessary, the F0-2AD2DA-2 terminal block can be removed to make removal of the module possible without disturbing field wiring.

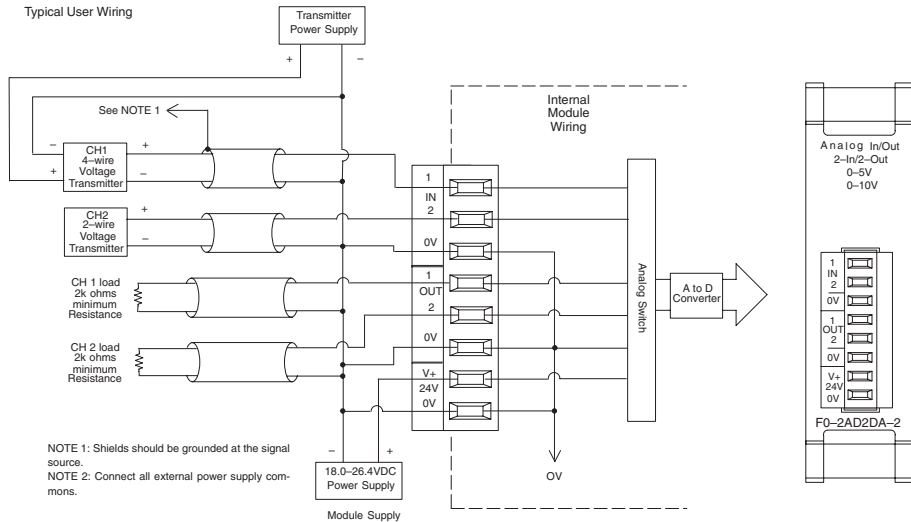

Module Operation

Input/Output Channel Scanning Sequence

The DL05 and DL06 read two channels of input and two channels of output data during each scan. The CPU supports special V-memory locations that are used to manage the data transfer. This is discussed in more detail on the following page, “Special V-memory Locations”.

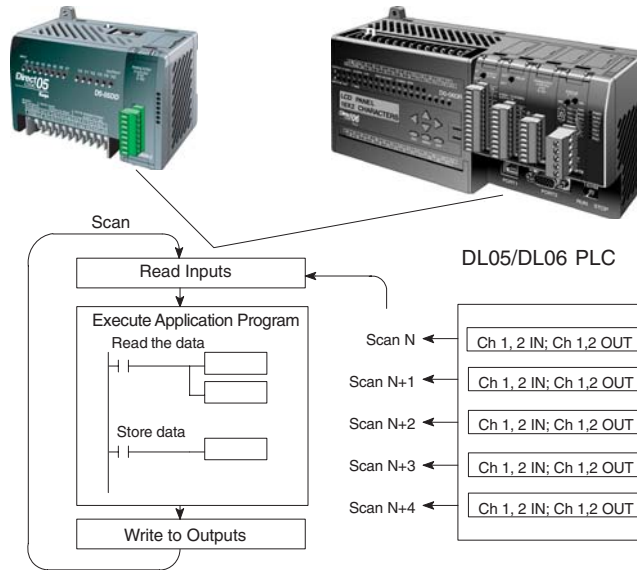

Analog Module Updates

Even though the channel updates to the CPU are synchronous with the CPU scan, the module asynchronously monitors the analog transmitter signals and converts each signal into a 12-bit binary representation. This enables the module to continuously provide accurate measurements without slowing down the discrete control logic in the RLL program.

The module takes approximately 10 milliseconds to sense 95% of the change in the analog signal. For the vast majority of applications, the process changes are much slower than these updates.



NOTE: If you are comparing other manufacturers' update times (step responses) with ours, please be aware that some manufacturers refer to the time it takes to convert the analog signal to a digital value. Our analog to digital conversion takes only a few microseconds. It is the settling time of the filter that is critical in determining the full update time. Our update time specification includes the filter settling time.

Special V-memory Locations

Formatting the Module Data

The DL05 and DL06 PLCs have three special V-memory locations assigned to their respective option slots. These V-memory locations allow you to:

- specify the data format (binary or BCD)
- specify the number of I/O channels to scan (2 input and 2 output channels for the F0-2AD2DA-2)
- specify the V-memory locations to store the input data
- specify the V-memory locations to store the output data

DL05 Data Formatting

The table below shows the special V-memory locations used by the DL05 PLC for the analog combination modules.

Analog Combination Module DL05 Special V-memory Locations	
Data Type and Number of I/O Channels	V7700
Input Storage Pointer	V7701
Output Storage Pointer	V7702

Structure of V7700

V-memory location 7700 is used for identifying the number of output channels, the number of input channels and the data type (binary or BCD). The low byte equals the number of output channels and the high byte equals the number of input channels. Either a 1 or a 2 will be entered to select the number of input and output channels to be used. A zero (0) entered for channel selection will cause the channel, either input or output, to be inoperative.

Loading a constant of 202 into V7700 identifies two input and two output analog channels, and sets the I/O data type to BCD.

Loading a constant of 8282 into V7700 identifies two input and two output analog channels, and sets the I/O data type to binary.

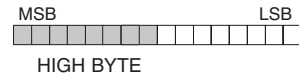
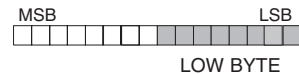

Structure of V7701

V7701 is a system parameter that points to a V-memory location used for storing analog input data. The V-memory location loaded in V7701 is an octal number identifying the first V-memory location for the analog input data. This V-memory location is user selectable. For example, loading O2000, using the LDA instruction, causes the pointer to write Ch 1's data value to V2000 and Ch 2's data value to V2001.

Structure of V7702

V7702 is a system parameter that points to a V-memory location used for storing analog output data. The V-memory location loaded in V7702 is an octal number identifying the first V-memory location for the analog output data. This V-memory location is user selectable. For example, loading O2010, using the LDA instruction, causes the pointer to write Ch 1's data value from V2010 and Ch 2's data value from V2011.

You will find an example program that loads appropriate values to V7700, V7701 and V7702 on page 6-10.

DL06 Data Formatting

Special V-memory locations are assigned to the four option module slots of the DL06 PLC. The table below shows these V-memory locations which can be used by the F0-2AD2DA-2.

Analog Combination Module DL06 Special V-memory Locations				
Slot No.	1	2	3	4
Number of Channels	V700	V710	V720	V730
Input Pointer	V701	V711	V721	V731
Output Pointer	V702	V712	V722	V732

Setup Data Type and Number of Channels

V-memory locations 700, 710, 720 and 730 are used for identifying the number of output channels, the number of input channels and the data type (binary or BCD). The low byte equals the number of output channels and the high byte equals the number of input channels. Enter a 1 or 2 to select the number of input and output channels to be used. A zero (0) entered for channel selection will cause the channel, either input or output, to be inoperative.

For example, with a module installed in slot 1 by loading a constant of 202 into V700 identifies two input and two output analog channels, and sets the I/O data type to BCD.

And, loading a constant of 8282 into V700 identifies two input and two output analog channels, and sets the I/O data type to binary.

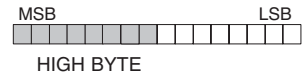

Input Storage Pointer

V-memory locations 701, 711, 721 and 731 are special locations used as a storage pointers for the analog input data. With the analog module installed in slot 1, the V-memory location loaded in V701 is an octal number identifying the first user V-memory location to read the analog input data. This V-memory location is user selectable. For example, loading O2000, using the LDA instruction, causes the pointer to write Ch 1's data value to V2000 and Ch 2's data value to V2001.

Output Storage Pointer

V-memory locations 702, 712, 722 and 732 are special locations used as storage pointer for the analog output data. With the analog module installed in slot 1, the V-memory location loaded in V702 is an octal number identifying the first user V-memory location to write the analog output data to. This V-memory location is user selectable. For example, loading O2010, using the LDA instruction, causes the pointer to write Ch 1's data value from V2010 and Ch 2's data value from V2011.

You will find an example program that loads appropriate values to V700, V701 and V702 on page 6-11.

Using the Pointer in Your Control Program

DL05 Pointer Method

The DL05 CPU examines the pointer values (the memory locations identified in V7700, V7701 and V7702) on the first scan only.

The example program below shows how to setup these locations for 2 input channels and 2 output channels. This rung can be placed anywhere in the ladder program or in the initial stage if you are using stage programming instructions.

This is all that is required to read the analog input data into V-memory locations. Once the data is in V-memory you can perform mathematical calculations with the data, compare the data against preset values, and so forth. V2000 and V2010 is used in the example but you can use any user V-memory location.

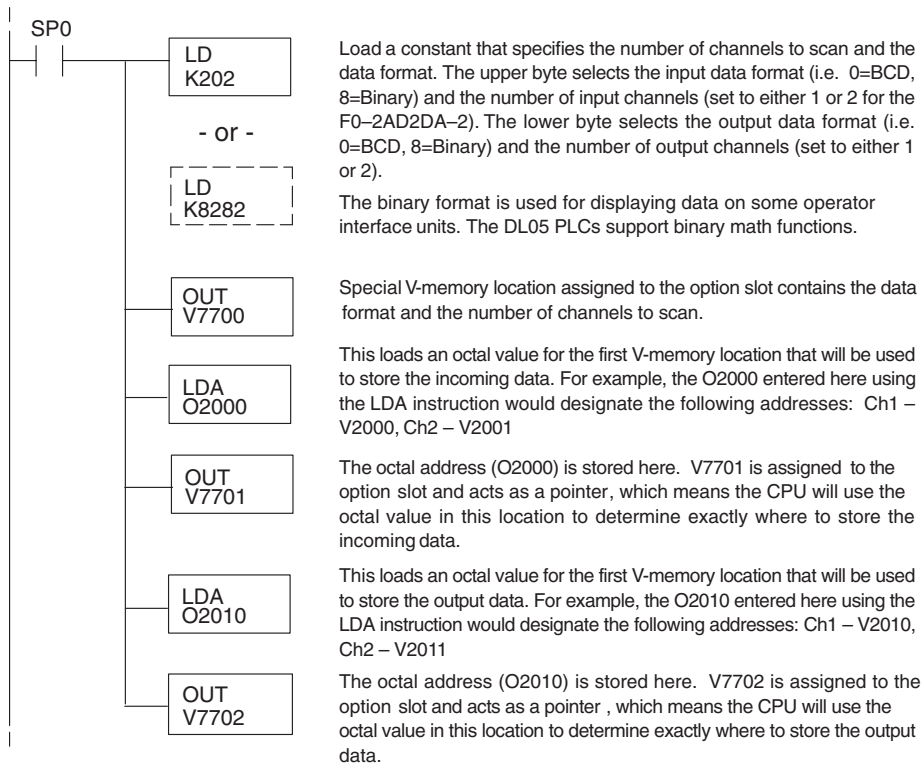

DL06 Pointer Method

Use the special V-memory table as a guide to setup the pointer values in the following example for the DL06. Slot 1 is the left most option slot. The CPU will examine the pointer values at these locations only after a mode transition, first scan only.

Analog Combination Module DL06 Special V-memory Locations				
Slot No.	1	2	3	4
Number of Channels	V700	V710	V720	V730
Input Pointer	V701	V711	V721	V731
Output Pointer	V702	V712	V722	V732

The F0-2AD2DA-2 can be installed in any available DL06 option slot. Using the example program from the previous page, but changing the V-memory addresses, the ladder diagram below shows how to setup these locations for 2 input channels and 2 output channels with the module installed in slot1 of the DL06. Use the above table to determine the pointer values if locating the module in any of the other slot locations. Place this rung anywhere in the ladder program or in the initial stage if you are using stage programming instructions.

Like the DL05 example, this logic is all that is required to read the analog input data into V-memory locations. Once the data is in V-memory you can perform mathematical calculations with the data, compare the data against preset values, and so forth. V2000 and V2010 is used in the example but you can use any user V-memory location.

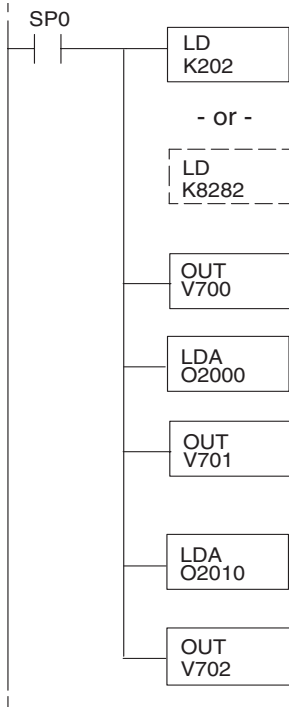

Loads a constant that specifies the number of channels to scan and the data format. The upper byte selects the input data format (i.e. 0=BCD, 8=Binary) and the number of input channels (set to either 1 or 2 for the F0-2AD2DA-2). The lower byte selects the output data format (i.e. 0=BCD, 8=Binary) and the number of output channels (set to either 1 or 2).

The binary format can be used for displaying data on some operator interface units and on the DL06 LCD display. The DL06 PLCs support binary math functions.

Special V-memory location assigned to the first option slot contains the data format and the number of channels to scan.

This loads an octal value for the first V-memory location that will be used to store the incoming data. For example, O2000 entered here using the LDA instruction would designate the following addresses: Ch1 - V2000, Ch2 - V2001

The octal address (O2000) is stored here. V701 is assigned to the first option slot and acts as a pointer, which means the CPU will use the octal value in this location to determine exactly where to store the incoming data.

This loads an octal value for the first V-memory location that will be used to store the output data. For example, O2010 entered here using the LDA instruction would designate the following addresses: Ch1 - V2010, Ch2 - V2011

The octal address (O2010) is stored here. V702 is assigned to the first slot and acts as a pointer, which means the CPU will use the octal value in this location to determine exactly where to store the output data.

Scale Conversions

Scaling the Input Data

Many applications call for measurements in engineering units, which can be more meaningful than raw data. Convert to engineering units using the formula shown to the right.

You may have to make adjustments to the formula depending on the scale you choose for the engineering units.

$$\text{Units} = A \frac{H-L}{4095} + L$$

H = High limit of the engineering unit range

L = Low limit of the engineering unit range

A = Analog value (0 – 4095)

For example, if you wanted to measure pressure (PSI) from 0.0 to 100.0 then you would have to multiply the analog value by 10 in order to imply a decimal place when you view the value with the programming software or a handheld programmer. Notice how the calculations differ when you use the multiplier.

Analog Value of 2024, slightly less than half scale, should yield 49.4 PSI.

Example without multiplier

$$\text{Units} = A \frac{H-L}{4095} + L$$

$$\text{Units} = 2024 \frac{100-0}{4095} + 0$$

$$\text{Units} = 49$$

Handheld Display

V 2001	V 2000
0000	0049

Example with multiplier

$$\text{Units} = 10 A \frac{H-L}{4095} + L$$

$$\text{Units} = 20240 \frac{100-0}{4095} + 0$$

$$\text{Units} = 494$$

Handheld Display

V 2001	V 2000
0000	0494

This value is more accurate

The Conversion Program

The following example shows how you would write the program to perform the engineering unit conversion from the input data format 0–4095. This example assumes the raw input data read at V2000 is in BCD format.

Note: this example uses SP1, which is always on. You could also use an X, C, etc. permissive contact.

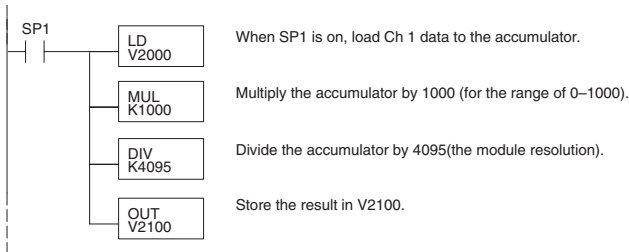

Output Conversion Program

The following example program shows how you would write the program to convert the engineering unit to the output data format 0–4095. This example assumes you have calculated or loaded the engineering unit values between 0–1000 in BCD format and stored them in V2300 and V2301 for channels 1 and 2 respectively. Both the DL05 and DL06 offer instructions that allow you to perform math operations using BCD format. It is usually easier to perform any math calculations in BCD and then convert the value to binary before you send the data to the module.

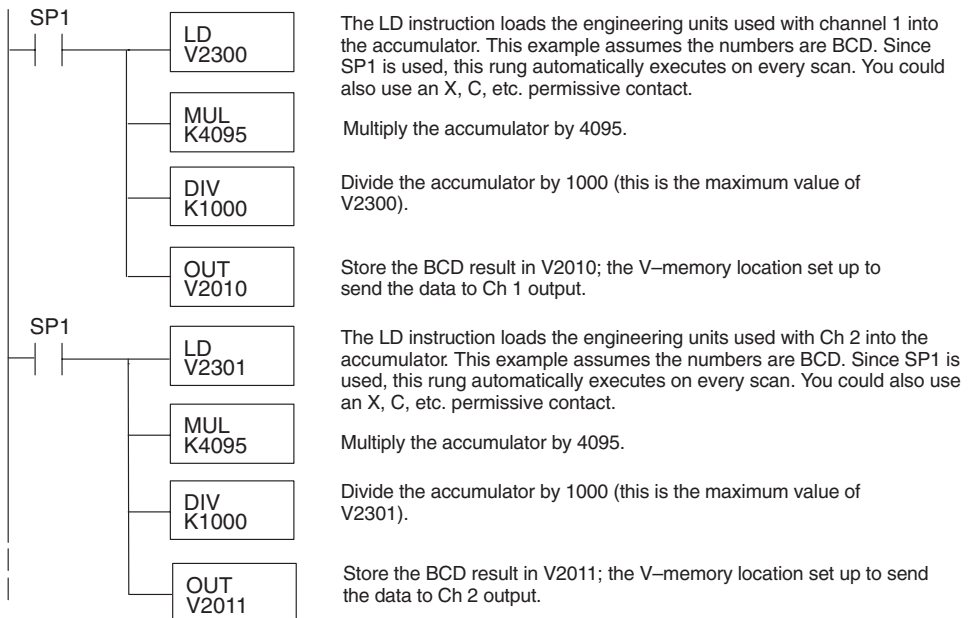

Analog and Digital Value Conversions

Sometimes it is useful to convert between the signal levels and the digital values. This is especially helpful during machine startup or troubleshooting. The following table provides formulas to make this conversion easier.

Range	If you know the digital value	If you know the analog signal level
0 to 5V	$A = \frac{5D}{4095}$	$D = \frac{4095}{5} (A)$
0 to 10V	$A = \frac{10D}{4095}$	$D = \frac{4095}{10} (A)$

For example, if you are using the 0–10V range and you need a 6V signal level, use this formula to determine the digital value (D) that will be stored in the V-memory location that contains the data.

$$D = \frac{4095}{10} (A)$$

$$D = \frac{4095}{10} (6V)$$

$$D = (409.5) (6)$$

$$D = 2457$$

Module Resolution

Analog Data Bits

The first twelve bits represent the analog data for both inputs and outputs in binary format.

Bit	Value	Bit	Value
0	1	6	64
1	2	7	128
2	4	8	256
3	8	9	512
4	16	10	1024
5	32	11	2048

MSB												LSB											
[] [] [] [] [] [] [] [] [] [] [] []												[] [] [] [] [] [] [] [] [] [] [] []											
												1 1 9 8 7 6 5 4 3 2 1 0											
												1 0											

[] = data bits

Resolution Details

Since the module has 12-bit resolution for both inputs and outputs, the analog signal is either converted into 4096 counts or a count value will produce a proportional analog output. In either situation the count range will be from 0–4095 (2¹²). For example, with an output range of 0 to 10V, send a 0 to get a 0V signal, and send 4095 to get a 10V signal. This is equivalent to a binary value of 0000 0000 0000 to 1111 1111 1111, or 000 to FFF hexadecimal.

Each count can also be expressed in terms of the signal level by using the following equation:

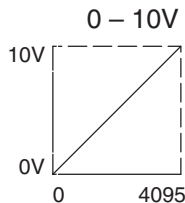

$$\text{Resolution} = \frac{H - L}{4095}$$

H = high limit of the signal range

L = low limit of the signal range

The following table shows the smallest detectable signal change that will result in one LSB change in the data or the amount of change in the output signal that each increment of the count value will produce.

Voltage Range	Signal Span	Divide By	Smallest detectable or Produced Change
0 to 5V	5 volts	4095	1.22 mV
0 to 10V	10 volts	4095	2.44 mV

Analog Input Ladder Logic Filter

PID Loops / Filtering:

Please refer to the “PID Loop Operation” chapter in the DL06 or DL05 User Manual for information on the built-in PV filter (DL05/06) and the ladder logic filter (DL06 only) shown below. A filter must be used to smooth the analog input value when auto tuning PID loops to prevent giving a false indication of loop characteristics.

Smoothing the Input Signal (DL06 only):

The filter logic can also be used in the same way to smooth the analog input signal to help stabilize PID loop operation or to stabilize the analog input signal value for use with an operator interface display, etc.

Warning: The built-in and logic filters are not intended to smooth or filter noise generated by improper field device wiring or grounding. Small amounts of electrical noise can cause the input signal to bounce considerably. Proper field device wiring and grounding must be done before attempting to use the filters to smooth the analog input signal.

Using Binary Data Format

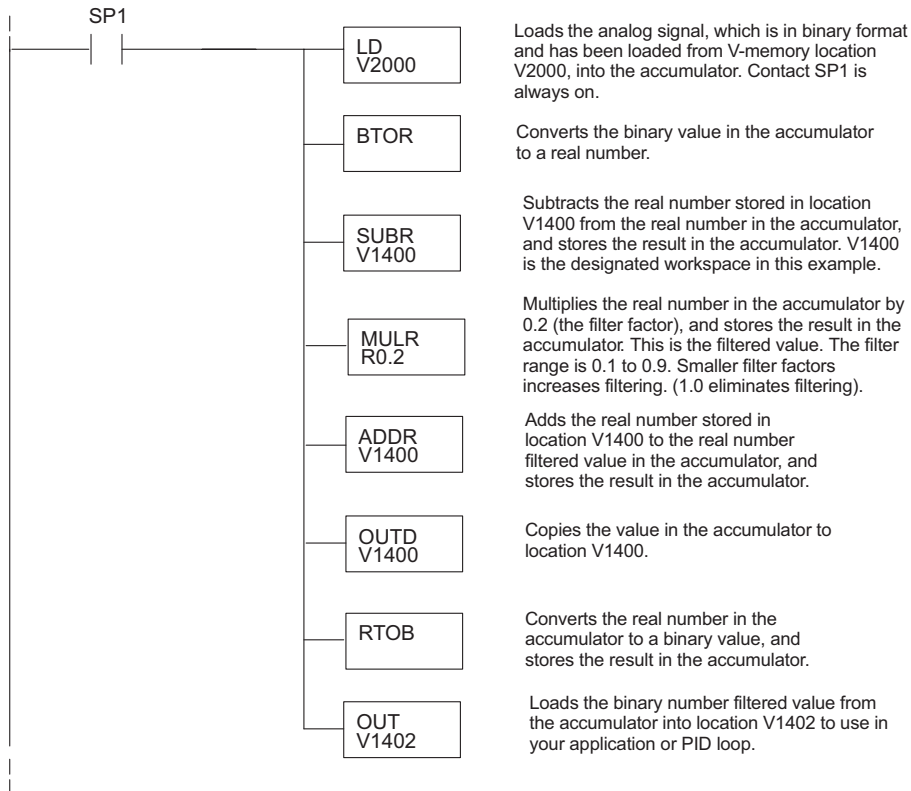



NOTE: Be careful not to do a multiple number conversion on a value. For example, if you are using the pointer method in BCD format to get the analog value, it must be converted to binary (BIN) as shown below. If you are using the pointer method in Binary format, the conversion to binary (BIN) instruction is not needed.

Using BCD Data Format

