

F0-04AD-1 4-Ch. ANALOG CURRENT INPUT



In This Chapter...

Module Specifications	3-2
Setting the Module Jumper	3-4
Connecting and Disconnecting the Field Wiring	3-4
Wiring Diagram	3-5
Module Operation	3-6
Special V-memory Locations	3-7
Using the Pointer in Your Control Program	3-9
Detecting Input Signal Loss	3-11
Scale Conversions	3-11
Special Relays	3-13
Module Resolution	3-15
Analog Input Ladder Logic Filter	3-16

Module Specifications

The F0-04AD-1 Analog Input module offers the following features:

- The DL05 and DL06 will read all four channels in one scan.
- The removable terminal block makes it possible to remove the module without disconnecting the field wiring.
- Analog inputs can be used as process variables for the four (4) PID loops in the DL05 and the eight (8) PID loops in the DL06 CPUs.
- Field device burn-out is detected on all four channels when 4–20mA range is selected.
- On-board active analog filtering and RISC-like microcontroller provide digital signal processing to maintain precise analog measurements in noisy environments.

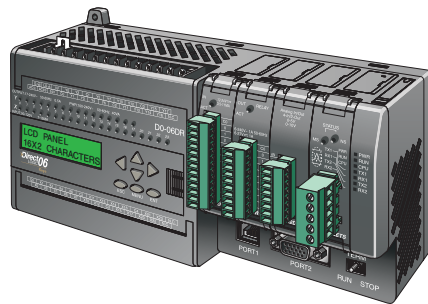
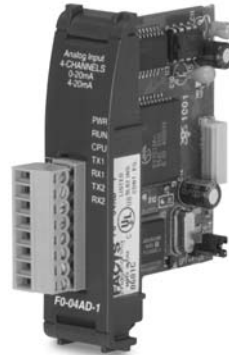

NOTE: The DL05 CPU's analog feature for this module requires **DirectSOFT32** Version 3.0c (or later) and firmware version 2.10 (or later). The DL06 requires **DirectSOFT32** version V4.0, build 16 (or later) and firmware version 1.00 (or later). See our website for more information: www.automationdirect.com.

The following tables provide the specifications for the F0-04AD-1 Analog Input Module. Review these specifications to make sure the module meets your application requirements.

Input Specifications	
Number of Channels	4, single ended (one common)
Input Range	0 to 20 mA or 4 to 20 mA current (jumper selectable)
Resolution	12 bit (1 in 4096) for 0-20mA, scaled for 4-20mA
Step Response	25.0 mS (typ) to 95% of full step change
Crosstalk	-80 dB, 1/2 count maximum *
Active Low-pass Filtering	-3 dB at 40Hz (-12 dB per octave)
Input Impedance	125 Ohm \pm 0.1%, 1/8 W current input
Absolute Maximum Ratings	-30 mA to +30 mA current input
Converter type	Successive approximation
Linearity Error (End to End)	\pm 2 counts maximum *
Input Stability	\pm 1 count *
Full Scale Calibration Error (Offset error not included)	\pm 10 counts maximum, @ 20mA current input*
Offset Calibration Error	\pm 5 counts maximum @ 4mA current input *
Maximum Inaccuracy	\pm 0.4% @ 25°C (77°F) \pm 0.85% 0 to 60°C (32 to 140°F)
Accuracy vs. Temperature	\pm 100 ppm/ °C maximum full scale calibration (including maximum offset change)
Recommended Fuse (external)	0.032 A Series 217 fast-acting current inputs

* One count in the specification table is equal to one least significant bit of the analog data value (1 in 4096).

General Specifications	
PLC Update Rate	4 channels per scan
16-bit Data Word	12 binary data bits 2 channel ID bits 2 diagnostic bits
Operating Temperature	0 to 60° C (32 to 140°F)
Storage Temperature	-20 to 70°C (-4 to 158°F)
Relative Humidity	5 to 95% (non-condensing)
Environmental air	No corrosive gases permitted
Vibration	MIL STD 810C 514.2
Shock	MIL STD 810C 516.2
Noise Immunity	NEMA ICS3-304
Power Budget Requirement	50 mA @ 5VDC (supplied by base)
Connector	Phoenix Mecano, Inc. Part No. AK1550/8-3.5 - green
Connector Wire Size	28 - 16 AWG
Connector Screw Torque	0.4 Nm
Connector Screwdriver Size	DN-SS1 (recommended)

Setting the Module Jumper

The position of jumper J3 determines the input signal level. You can choose between 4–20mA and 0–20mA. The module ships with the jumper not connecting the two pins. In this position, the expected input signal is 4–20mA. To select 0–20mA signals, use the jumper to cover both pins.

The default jumper setting selects a 4–20mA signal source. The default jumper setting does not connect the two pins.

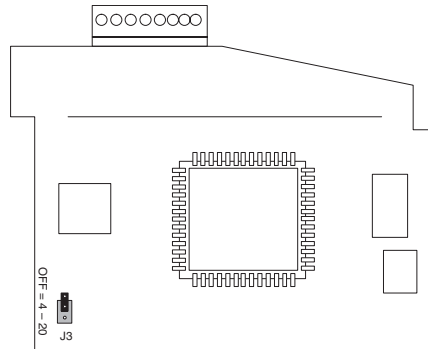

WARNING: Before removing the analog module or the terminal block on the face of the module, disconnect power to the PLC and all field devices. Failure to disconnect power can result in damage to the PLC and/or field devices.

Connecting and Disconnecting the Field Wiring

Wiring Guidelines

Your company may have guidelines for wiring and cable installation. If so, you should check those before you begin the installation. Here are some general things to consider:

- Use the shortest wiring route whenever possible.
- Use shielded wiring and ground the shield at the transmitter source. *Do not* ground the shield at both the module and the source.
- Do not run the signal wiring next to large motors, high current switches, or transformers. This may cause noise problems.
- Route the wiring through an approved cable housing to minimize the risk of accidental damage. Check local and national codes to choose the correct method for your application.

The F0-04AD-1 does not supply power to field devices. You will need to power transmitters separately from the PLC.

To remove the terminal block, disconnect power to the PLC and the field devices. Pull the terminal block firmly until the connector separates from the module.

You can remove the analog module from the PLC by folding out the retaining tabs at the top and bottom of the module. As the retaining tabs pivot upward and outward, the module's connector is lifted out of the PLC socket. Once the connector is free, you can lift the module out of its slot.

Wiring Diagram

Use the following diagram to connect the field wiring. If necessary, the F0-04AD-1 terminal block can be removed to make removal of the module possible without disturbing field wiring.

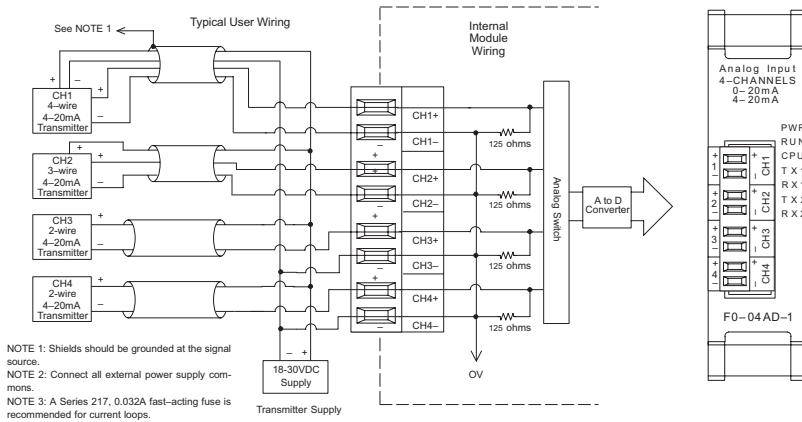

Current Loop Transmitter Impedance

Manufacturers of transmitters and transducers specify a wide variety of power sources for their products. Follow the manufacturer's recommendations.

In some cases, manufacturers specify a minimum loop or load resistance that must be used with the transmitter. The F0-04AD-1 provides 125 ohm resistance for each channel. If your transmitter requires a load resistance below 125 ohms, you do not have to make any changes. However, if your transmitter requires a load resistance higher than 125 ohms, you need to add a resistor in series with the module.

Consider the following example for a transmitter being operated from a 30 VDC supply with a recommended load resistance of 750 ohms. Since the module has a 125 ohm resistor, you need to add an additional resistor.

$$R = Tr - Mr$$

$$R = 750 - 125$$

$$R \geq 625$$

$R =$ resistor to add
 $Tr =$ Transmitter Requirement
 $Mr =$ Module resistance (internal 125 ohms)

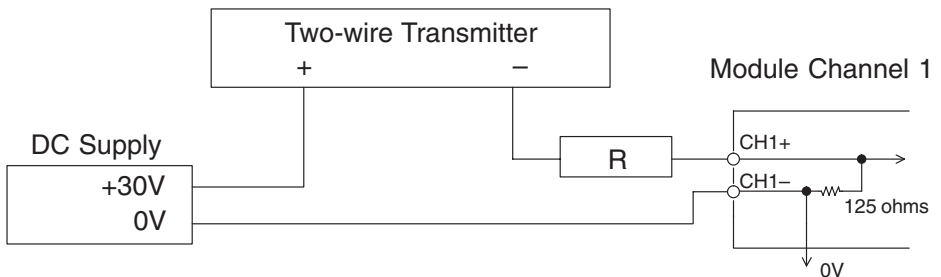

Module Operation

Channel Scanning Sequence

The DL05 and DL06 will read all four channels of input data during each scan. Each CPU supports special V-memory locations that are used to manage the data transfer. This is discussed in more detail beginning in the section on “Special V-memory Locations”.

3

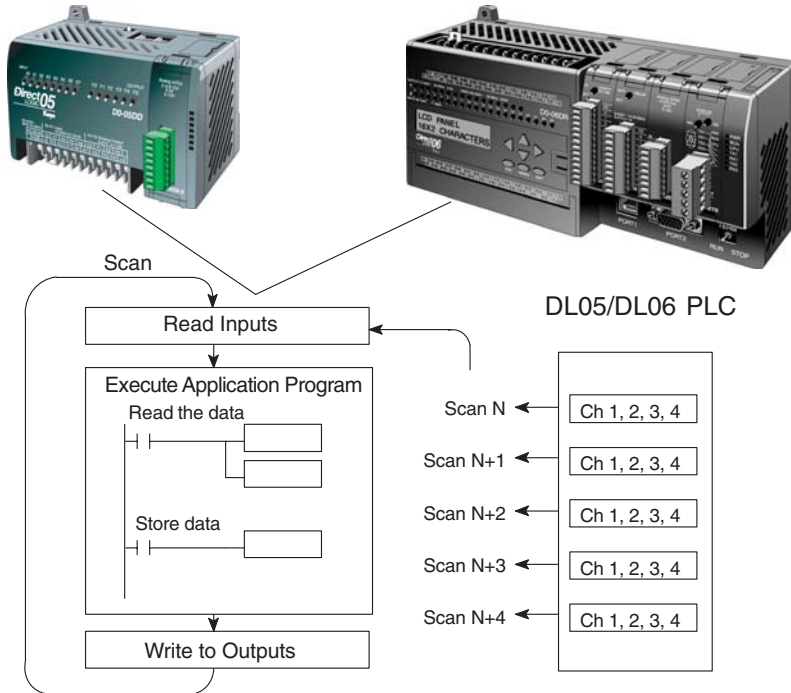

Analog Module Updates

Even though the channel updates to the CPUs are synchronous with the CPU scan, the module asynchronously monitors the analog transmitter signals and converts each signal into a 12-bit binary representation. This enables the module to continuously provide accurate measurements without slowing down the discrete control logic in the RLL program.

The module takes approximately 25 milliseconds to sense 95% of the change in the analog signal. For the vast majority of applications, the process changes are much slower than these updates.



NOTE: If you are comparing other manufacturers' update times (step responses) with ours, please be aware that some manufacturers refer to the time it takes to convert the analog signal to a digital value. Our analog to digital conversion takes only a few microseconds. It is the settling time of the filter that is critical in determining the full update time. Our update time specification includes the filter settling time.

Special V-memory Locations

Formatting the Module Data

The DL05 and DL06 PLCs have special V-memory locations assigned to their respective option slots. These V-memory locations allow you to:

- specify the data format (binary or BCD)
- specify the number of channels to scan (4 channels for the F0-04AD-1)
- specify the V-memory locations to store the input data

DL05 Data Formatting

The table below shows the special V-memory locations used by the DL05 PLC for the F0-04AD-1.

Analog Input Module DL05 Special V-memory Locations	
Data Type and Number of Channels	V7700
Storage Pointer	V7701

Structure of V7700

Special V-memory location 7700 identifies that a F0-04AD-1 module is installed in the DL05 option slot and the data type to be either binary or BCD.

Loading a constant of 400 into V7700 identifies a 4 channel analog input module is installed in the DL05 option slot, and reads the input data values as BCD numbers.

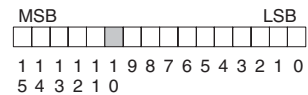

Loading a constant of 8400 into V7700 identifies a 4 channel analog input module is installed in the DL05 option slot, and reads the input data values as binary numbers.

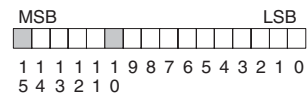

Structure of V7701

V7701 is a system V-memory location used as a pointer to a user V-memory location where the analog input data is stored. The V-memory location loaded into V7701 is an octal number identifying the first user V-memory location for reading the analog input data. This V-memory location is user selectable. For example, loading O2000 causes the pointer to write Ch 1's data value to V2000, Ch 2's data value to V2001, Ch 3's data value to V2002, and Ch 4's data value to V2003.

You will find an example program that loads appropriate values to V7700 and V7701 on page 3-9.

DL06 Data Formatting

Special V-memory locations are assigned to the four option slots of the DL06 PLC. The table below shows these V-memory locations which can be used to setup the F0-04AD-1.

Analog Input Module DL06 Special V-memory Locations				
Slot No.	1	2	3	4
Data Type and Number of Channels	V700	V710	V720	V730
Storage Pointer	V701	V711	V721	V731

Setup Data Type and Number of Channels

V-memory locations 700, 710, 720 and 730 are used to set the data format to be read in either binary or BCD, and to set the number of channels that will be active.

For example, the F0-04AD-1 is installed in slot 1. Loading a constant of 400 into V700 sets 4 channels active, and the input data value is read as a BCD number.

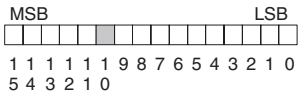

With the F0-4AD-1 in slot 1, loading a constant of 8400 into V700 sets 4 channels active, and the input data value is read as a binary number.

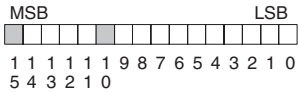

Storage Pointer Setup

V-memory locations 701, 711, 721 and 731 are special locations used as storage pointers. A V-memory address is loaded into this location as an octal number identifying the first user V-memory location for the analog input data. This V-memory location is user selectable. For example, loading O2000 causes the pointer to write Ch 1's data value to V2000, Ch 2's data value to V2001, Ch 3's data value to V2002, and Ch 4's data value to V2003.

You will find an example program that loads appropriate values to V700 and V701 beginning on page 3-10.

Using the Pointer in Your Control Program

DL05 Pointer Method

The DL05 CPU examines the pointer values (the memory locations identified in V7700 and V7701) on the first scan only.

The example program below shows how to setup these locations. This rung can be placed anywhere in the ladder program or in the initial stage if you are using stage programming instructions.

This is all that is required to read the analog input data into V-memory locations. Once the data is in V-memory you can perform math on the data, compare the data against preset values, and so forth. V2000 is used in the example but you can use any user V-memory location.

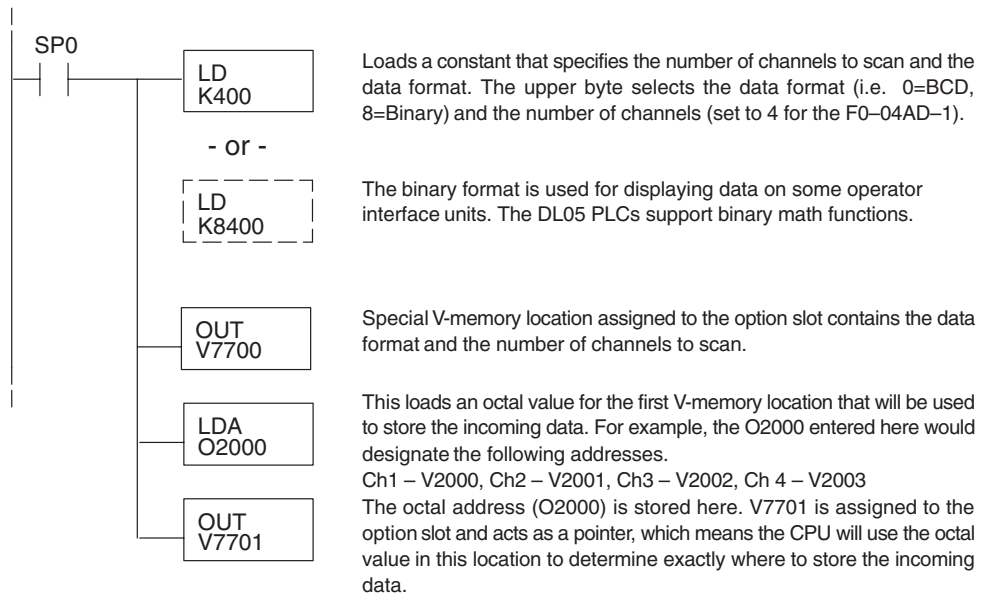

DL06 Pointer Method

Use the special V-memory table below as a guide to setup the storage pointer in the following example for the DL06. Slot 1 is the left most option slot. The CPU will examine the pointer values at these locations only after a mode transition.

Analog Input Module DL06 Special V-memory Locations				
Slot No.	1	2	3	4
No. of Channels	V700	V710	V720	V730
Input Pointer	V701	V711	V721	V731

The F0-04AD-1 can be installed in any available DL06 option slot. Using the example program from the previous page, but changing the V-memory addresses, the ladder diagram below shows how to setup these locations with the module installed in slot 1 of the DL06. Use the above table to determine the pointer values if locating the module in any of the other slot locations. Place this rung anywhere in the ladder program or in the initial stage if you are using stage programming instructions.

Like the DL05 example, this logic is all that is required to read the analog input data into V-memory locations. Once the data is in V-memory you can perform mathematical calculations with the data, compare the data against preset values, and so forth. V2000 is used in the example but you can use any user V-memory location.

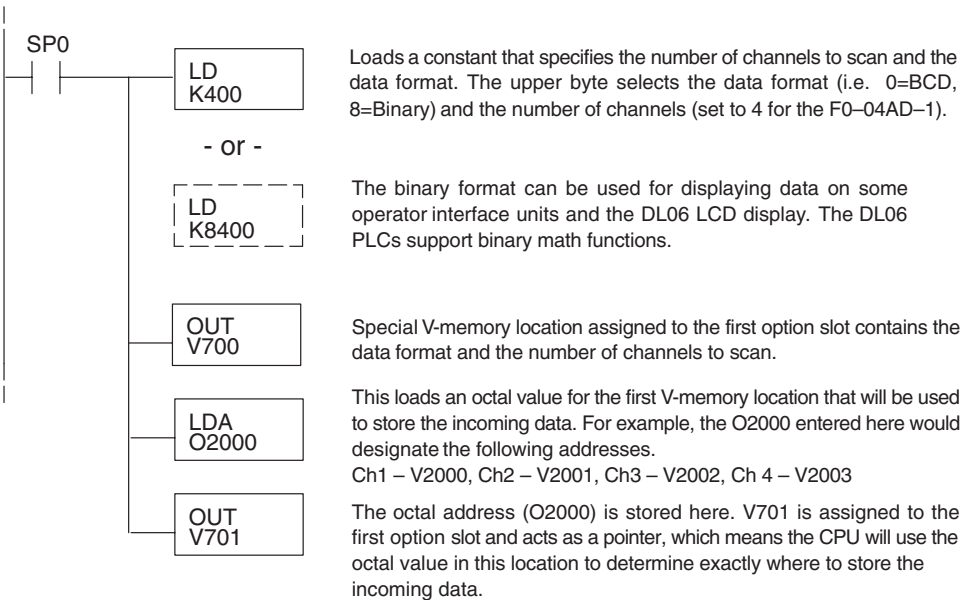

Detecting Input Signal Loss

Analog Signal Loss

The F0-04AD-1 analog module can sense the loss of analog input signals in 4-20mA loops. The Special Relays described on page 3-14 allow you to use this feature in your ladder program. For example, in the rung below SP610 is used to pull-in coil Y1, which would be used to open or close an external circuit.



The Special Relay SP610 detects a loss of input signal to channel 1. Use SP610 to trigger an alarm or shut down a machine.



NOTE: The F0-04AD-1 analog module cannot sense the loss of analog input signals in 0-20mA loops. See page 3-4 for information about setting the jumper to select your input type.

Scale Conversions

Scaling the Input Data

Many applications call for measurements in engineering units, which can be more meaningful than raw data. Convert to engineering units using the formula shown to the right.

You may have to make adjustments to the formula depending on the scale you choose for the engineering units.

For example, if you wanted to measure pressure (PSI) from 0.0 to 99.9 then you would have to multiply the analog value by 10 in order to imply a decimal place when you view the value with the programming software or a handheld programmer. Notice how the calculations differ when you use the multiplier.

Analog Value of 2024, slightly less than half scale, should yield 49.4 PSI

Example without multiplier

$$\text{Units} = A \frac{H-L}{4095} + L$$

$$\text{Units} = 2024 \frac{100-0}{4095} + 0$$

$$\text{Units} = 49$$

Handheld Display

V 2001	V 2000
0000	0049

Example with multiplier

$$\text{Units} = 10 A \frac{H-L}{4095} + L$$

$$\text{Units} = 20240 \frac{100-0}{4095} + 0$$

$$\text{Units} = 494$$

Handheld Display

V 2001	V 2000
0000	0494

This value is more accurate

The Conversion Program

The following example shows how you would write the program to perform the engineering unit conversion. This example assumes you have BCD data loaded into the appropriate V-memory locations using instructions that apply for the model of CPU you are using.

Note: this example uses SP1, which is always on. You could also use an X, C, etc. permissive contact.

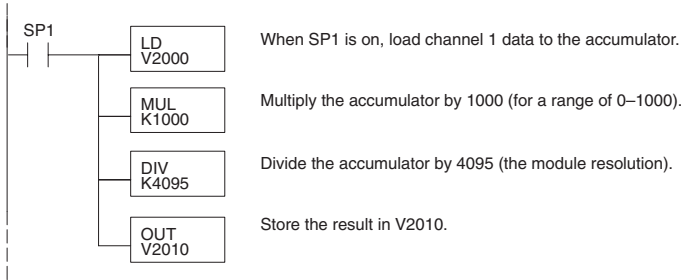

Analog and Digital Value Conversions

Sometimes it is useful to convert between the signal levels and the digital values. This is especially helpful during machine startup or troubleshooting. The following table provides formulas to make this conversion easier.

Range	If you know the digital value	If you know the analog signal level
4 to 20mA	$A = \frac{16D}{4095} + 4$	$D = \frac{4095}{16} (A - 4)$
0 to 20mA	$A = \frac{20D}{4095}$	$D = \frac{4095}{16}$

For example, if you have measured the signal as 10mA, you can use the formula to determine the digital value that will be stored in the V-memory location that contains the data.

$$D = \frac{4095}{16} (A - 4)$$

$$D = \frac{4095}{16} (10\text{mA} - 4)$$

$$D = (255.93) (6) \quad D = 1536$$

Special Relays

The list of other Special Relays associated with the DL05 and DL06 PLCs are contained in the DL05 User Manual and the DL06 User Manual. The following special relays are new and relate to the status of the F0-04AD-1 module or one of its input channels.

DL05 Special Relays

DL05 Special Relays			
SP600	Chan 1 input type	0 = 0 - 20mA	1 = 4 - 20mA
SP601	Chan 2 input type	0 = 0 - 20mA	1 = 4 - 20mA
SP602	Chan 3 input type	0 = 0 - 20mA	1 = 4 - 20mA
SP603	Chan 4 input type	0 = 0 - 20mA	1 = 4 - 20mA
SP610	Chan 1 input open	1 = xmitter signal open	0 = xmitter signal good
SP611	Chan 2 input open	1 = xmitter signal open	0 = xmitter signal good
SP612	Chan 3 input open	1 = xmitter signal open	0 = xmitter signal good
SP613	Chan 4 input open	1 = xmitter signal open	0 = xmitter signal good

DL06 SpecialRelays

DL06 Special Relays			
Slot 1			
SP140	Chan 1 input type	0 = 0 - 20mA	1 = 4 - 20mA
SP141	Chan 2 input type	0 = 0 - 20mA	1 = 4 - 20mA
SP142	Chan 3 input type	0 = 0 - 20mA	1 = 4 - 20mA
SP143	Chan 4 input type	0 = 0 - 20mA	1 = 4 - 20mA
SP150	Chan 1 input open	1 = xmitter signal open	0 = xmitter signal good
SP151	Chan 2 input open	1 = xmitter signal open	0 = xmitter signal good
SP152	Chan 3 input open	1 = xmitter signal open	0 = xmitter signal good
SP153	Chan 4 input open	1 = xmitter signal open	0 = xmitter signal good

Slot 2			
SP240	Chan 1 input type	0 = 0 - 20mA	1 = 4 - 20mA
SP241	Chan 2 input type	0 = 0 - 20mA	1 = 4 - 20mA
SP242	Chan 3 input type	0 = 0 - 20mA	1 = 4 - 20mA
SP243	Chan 4 input type	0 = 0 - 20mA	1 = 4 - 20mA
SP250	Chan 1 input open	1 = xmitter signal open	0 = xmitter signal good
SP251	Chan 2 input open	1 = xmitter signal open	0 = xmitter signal good
SP252	Chan 3 input open	1 = xmitter signal open	0 = xmitter signal good
SP253	Chan 4 input open	1 = xmitter signal open	0 = xmitter signal good

DL06 Special Relays (cont'd)			
Slot 3			
SP340	Chan 1 input type	0 = 0 - 20mA	1 = 4 - 20mA
SP341	Chan 2 input type	0 = 0 - 20mA	1 = 4 - 20mA
SP342	Chan 3 input type	0 = 0 - 20mA	1 = 4 - 20mA
SP343	Chan 4 input type	0 = 0 - 20mA	1 = 4 - 20mA
SP350	Chan 1 input open	1 = xmitter signal open	0 = xmitter signal good
SP351	Chan 2 input open	1 = xmitter signal open	0 = xmitter signal good
SP352	Chan 3 input open	1 = xmitter signal open	0 = xmitter signal good
SP353	Chan 4 input open	1 = xmitter signal open	0 = xmitter signal good

Slot 4			
SP440	Chan 1 input type	0 = 0 - 20mA	1 = 4 - 20mA
SP441	Chan 2 input type	0 = 0 - 20mA	1 = 4 - 20mA
SP442	Chan 3 input type	0 = 0 - 20mA	1 = 4 - 20mA
SP443	Chan 4 input type	0 = 0 - 20mA	1 = 4 - 20mA
SP450	Chan 1 input open	1 = xmitter signal open	0 = xmitter signal good
SP451	Chan 2 input open	1 = xmitter signal open	0 = xmitter signal good
SP452	Chan 3 input open	1 = xmitter signal open	0 = xmitter signal good
SP453	Chan 4 input open	1 = xmitter signal open	0 = xmitter signal good

Module Resolution

Analog Data Bits

The first twelve bits represent the analog data in binary format.

Bit	Value	Bit	Value
0	1	6	64
1	2	7	128
2	4	8	256
3	8	9	512
4	16	10	1024
5	32	11	2048

MSB												LSB											
[] [] [] [] [] [] [] [] [] [] [] []												[] [] [] [] [] [] [] [] [] [] [] []											
												1 1 9 8 7 6 5 4 3 2 1 0											
												1 0											

□ = data bits

3

Resolution Details

Since the module has 12-bit resolution, the analog signal is converted into 4096 counts ranging from 0 - 4095 (2^{12}). For example, a 4mA signal would be 0 and a 20mA signal would be 4095. This is equivalent to a binary value of 0000 0000 0000 to 1111 1111 1111, or 000 to FFF hexadecimal.

Each count can also be expressed in terms of the signal level by using the following equation:

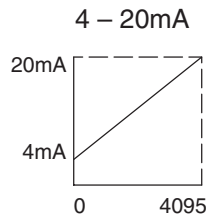

$$\text{Resolution} = \frac{H - L}{4095}$$

H = high limit of the signal range

L = low limit of the signal range

The following table shows the smallest detectable signal change that will result in one LSB change in the data value for each increment of the signal change.

mA Range	Signal Span (H - L)	Divide By	Smallest Detectable Change
4 to 20mA	16mA	4095	3.907 μ A
0 to 20mA	10mA	4095	4.884 μ A

Analog Input Ladder Logic Filter

PID Loops / Filtering:

Please refer to the “PID Loop Operation” chapter in the DL06 or DL05 User Manual for information on the built-in PV filter (DL05/06) and the ladder logic filter (DL06 only) shown below. A filter must be used to smooth the analog input value when auto tuning PID loops to prevent giving a false indication of loop characteristics.

Smoothing the Input Signal (DL06 only):

The filter logic can also be used in the same way to smooth the analog input signal to help stabilize PID loop operation or to stabilize the analog input signal value for use with an operator interface display, etc.



Warning: The built-in and logic filters are not intended to smooth or filter noise generated by improper field device wiring or grounding. Small amounts of electrical noise can cause the input signal to bounce considerably. Proper field device wiring and grounding must be done before attempting to use the filters to smooth the analog input signal.

Using Binary Data Format

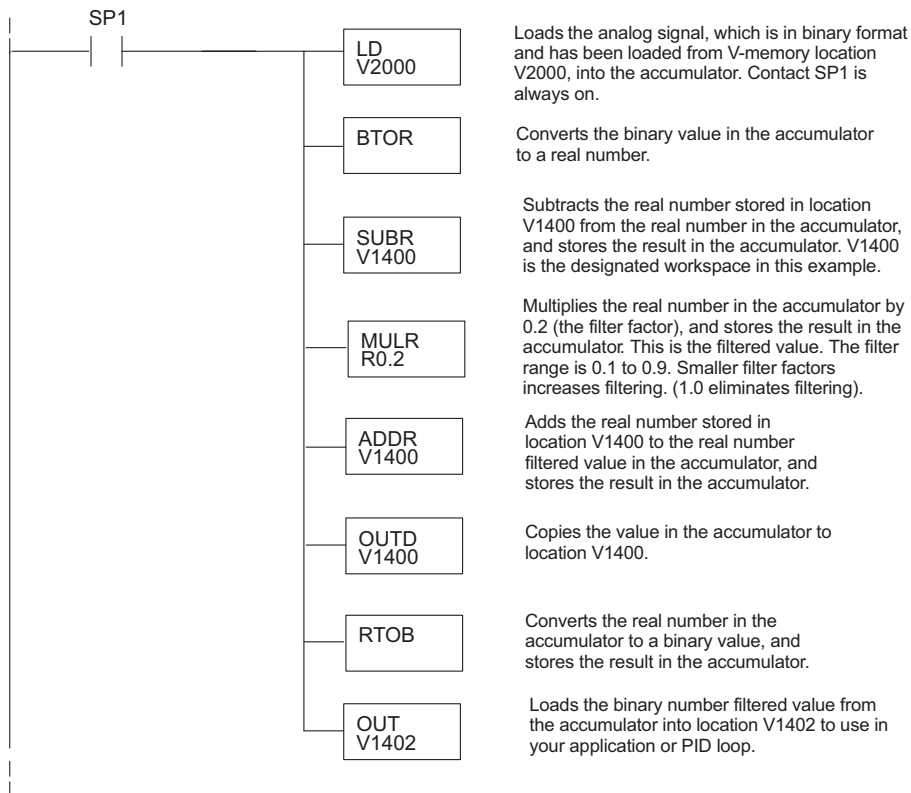



NOTE: Be careful not to do a multiple number conversion on a value. For example, if you are using the pointer method in BCD format to get the analog value, it must be converted to binary (BIN) as shown below. If you are using the pointer method in Binary format, the conversion to binary (BIN) instruction is not needed.

Using BCD Data Format

